

# TREMLOCK<sup>®</sup>T-238

## INSTALLATION GUIDE

**TREMCO**

ROOFING & BUILDING MAINTENANCE

PAGE NUMBER:	DETAIL DESCRIPTION
A-1.....	TABLE OF CONTENTS
A-2.....	GENERAL NOTES
B-1.....	GENERAL INFORMATION
C-1.....	EAVE DRIP DETAIL
C-2.....	EAVE DRIP with GUTTER DETAIL
C-3 & C-4.....	FIXED RIDGE DETAIL
C-5 & C-6.....	FIXED HIGH EAVE DETAIL
C-7 & C-8.....	FIXED HIGH-SIDE TIE-IN DETAIL
C-9.....	FLOATING RAKE DETAIL
C-10.....	FLOATING RAKE DETAIL (ALTERNATE)
C-11.....	FLOATING SIDE-WALL TIE-IN DETAIL
C-12 & C-13.....	VALLEY DETAIL
C-14 & C-15.....	VALLEY DETAIL (ALTERNATE)
C-16 & C-17.....	HIP DETAIL
C-18.....	DEKTITE DETAIL
C-19 & C-20.....	TRIM LAP DETAILS

The details shown on the following pages are suggestions or guidelines for installing the T238 roof panel system. The installation details shown here are proven methods of construction, but they are not intended to cover all building requirements, designs or codes. The details may require changes or revisions due to individual project conditions. In addition, other details may be perfectly acceptable for use. Please contact Tremco Inc. Metal Group for assistance in determining if a detail is acceptable.

Installation procedures shall be in accordance with the manufacturer's printed instructions, details or approved shop drawings. Installers should thoroughly familiarize themselves with all instructions prior to beginning the installation process.

The designer/installer is responsible to ensure the following:

That the details here meet the particular building requirements.

Awareness of and allowance for expansion/contraction of the roof panels.

That adequate water tightness is maintained.

That a proper uniform substructure is used to avoid panel distortion and that the substructure meets necessary code requirements.

That all supporting members have been examined and are straight, level and plumb.

Tremco Inc. can provide all flashings and accessories shown in the installation drawings unless noted otherwise. Panels, flashing and trim shall be installed true and in proper alignment with any exposed fasteners equally spaced for the best appearance. Sealant shall be field applied on a clean, dry surface.

Some field cutting and fitting of panels and flashings is to be expected and to be considered a part of normal installation work. Workmanship shall be of the best industry standards and with installation performed by experienced metal craftsmen.

Oil canning of metal panels is inherent in the product and is not a cause for rejection. Plank or Striated panels are recommended as to reduce the appearance of oil canning.

Contents of this manual are subject to change without notice.

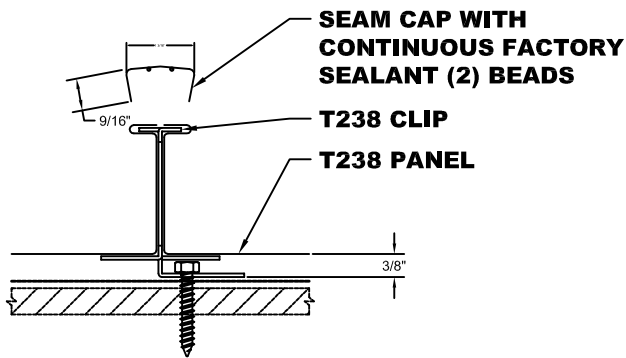

**SEAM ENGAGEMENT**

NOTE:  
ALL DIMENSIONS ARE APPROXIMATE.  
SLIGHT DIFFERENCES IN THE FIELD  
ARE ACCEPTABLE.

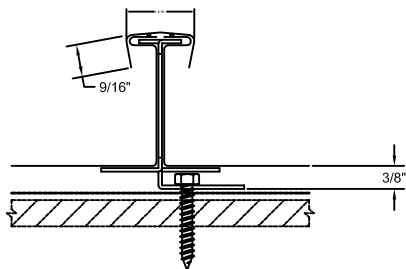

**BEFORE SEAMING**

NOTE:  
ALL DIMENSIONS ARE APPROXIMATE.  
SLIGHT DIFFERENCES IN THE FIELD  
ARE ACCEPTABLE.

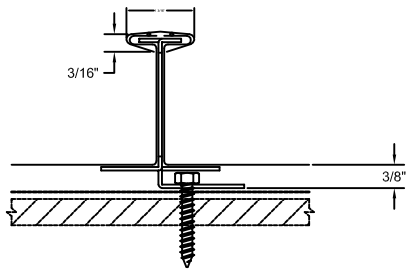

**AFTER SEAMING**

NOTE:  
ALL DIMENSIONS ARE APPROXIMATE.  
SLIGHT DIFFERENCES IN THE FIELD  
ARE ACCEPTABLE.

**NOTE:**

Mechanical seamers and hand seamers are available for rental through Tremco Inc. approved seamer supplier at the following website. Go to: <http://www.usaseamers.com>

**!!!ATTENTION!!!**

If a panel or seam becomes damaged, the Installer can rent a "de-seamer" through the same website listed above.

**ATTENTION**

**BEFORE STARTING THE SEAMING OPERATION. FAILURE TO ADHERE TO THESE INSTRUCTIONS MAY RESULT IN PERSONAL INJURY AND DAMAGE TO THE SEAMER AND/OR PANELS. THE ERECTOR WILL BE HELD LIABLE FOR ANY COSTS INCURRED FOR REPLACEMENT OR REPAIR.**

**PRE-SEAMING INFORMATION**

1. Locate seamer box. Check to make sure you received an electric seamer, parts box, return shipping label and an information booklet. If not, please call our Technical Services Department. (Hand Seamers must be rented.)
2. Locate power source and check against power requirements in the information booklet.
3. Check seams for proper engagement.
4. Clean dirt, debris and excess sealant from seams and panel surfaces to avoid interfering with the seaming operation.

**HAND SEAMING OPERATION**

**!!!ATTENTION!!!**

It is critical that the panel seams are crimped and folded before using the electric seamer. Failure to follow these guidelines will result in damaged seams.

To begin seaming, set the hand seamer on the seam. Align the edge of the hand seamer about one to two inches past the edge of the panel. Crimp the panel 3 to 4 times along the seam for a total of 12" at the eave and 5 or 6 times along the seam for a total of 18" at the ridge and then at every clip.

I:\Manuals\maxima\_iso4.jpg

**CAUTION:** The use of any seaming machine or tools other than that recommended by the manufacturer, may damage the panels, void all warranties and will void all engineering data.

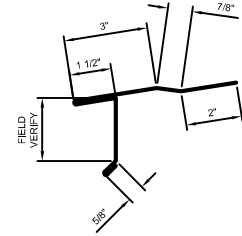
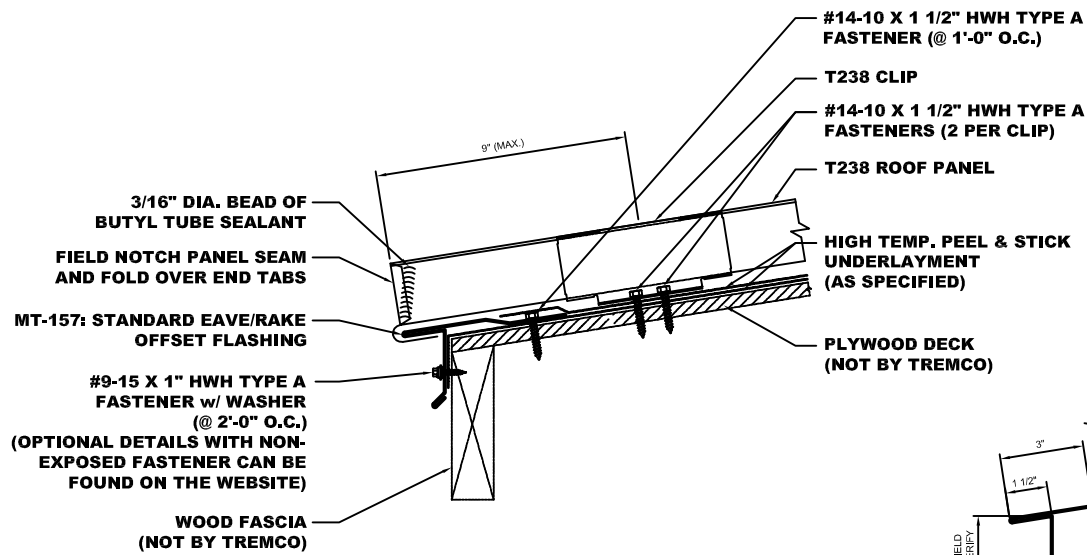

**STANDARD EAVE/RAKE  
OFFSET FLASHING**

- NOTES:**
1. Standard Eave/Rake Offset Flashing to run from out of wall to out of wall.
  2. Attach Standard Eave/Rake Offset Flashing to decking with #14-10 x 1 1/2" HWH Type A Fastener @ 1'-0" O.C.
  3. Attach Standard Eave/Rake Offset Flashing to the Wood Fascia with #9-15 x 1" HWH Type A Fastener with Washer @ 2'-0" O.C.
  4. Trim pieces lap 2". Apply 3/32" x 3/8" Butyl Tape or Butyl Tube Sealant in trim laps.
  5. Place a 3/16" Dia. Bead of Butyl Tube Sealant to leading edge of T238 panel.
  6. Field Notch panel seam and fold over end tabs.

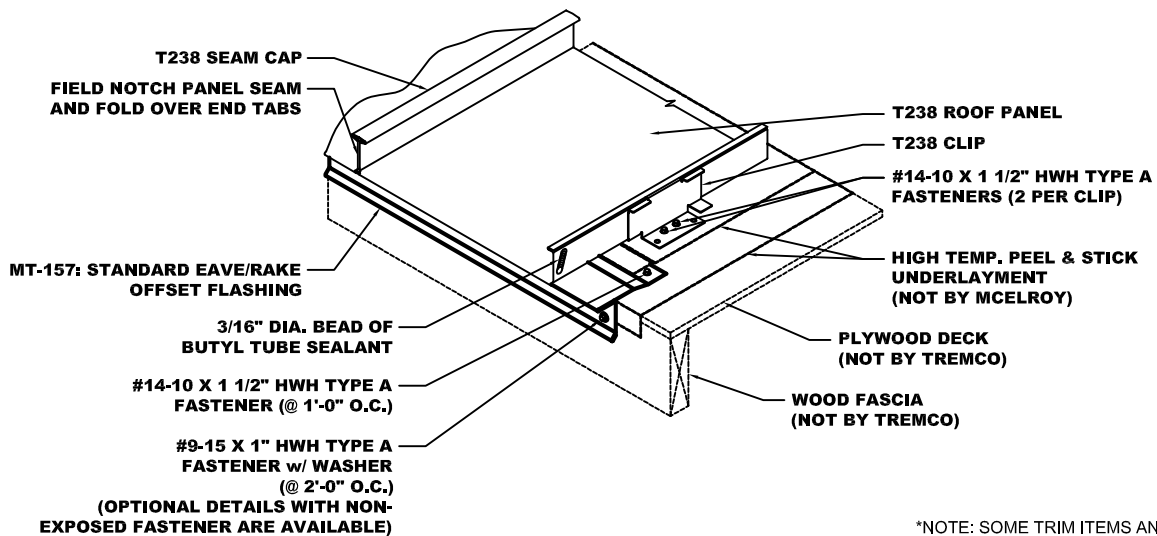

\*NOTE: SOME TRIM ITEMS AND FASTENERS HAVE BEEN REMOVED FOR CLARITY OF ISOMETRIC DETAIL.

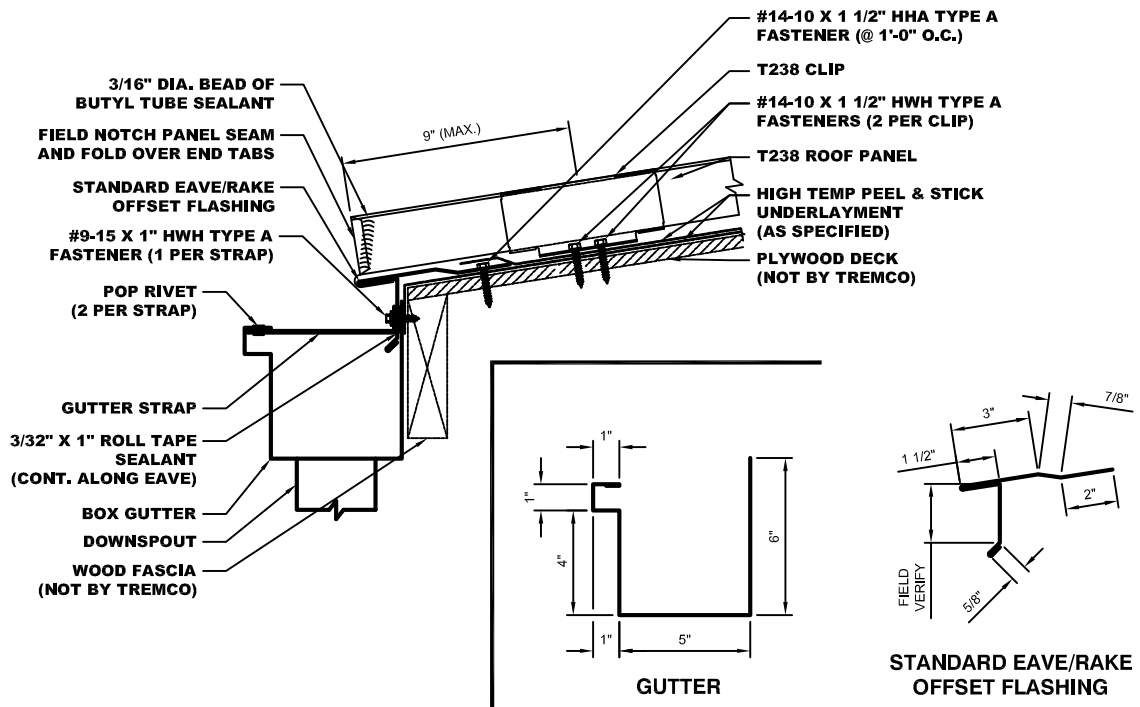

2. Apply a continuous bead of 3/32" x 1" Roll Tape Sealant to the inside vertical leg of the (Gutter). Attach (Gutter Straps) to Gutter with (2) Pop Rivets as shown in detail.
3. Attach (Standard Eave/Rake Offset Flashing) to decking with #14-10 x 1 1/2" HWH Type A Fastener @ 1'-0" O.C. Slide vertical leg of Gutter behind (Standard Offset Eave Flashing) and fasten through (Gutter Strap), (Standard Eave/Rake Offset Flashing), Tape Sealant and Gutter with #9-15 x 1" HWH Type A Fastener into Fascia Board required Gutter Strap Spacing.
4. Trim pieces lap 2". Apply 3/32" x 3/8" Butyl Tape or Butyl Tube Sealant in trim laps.
5. Place a 3/16" Dia. Bead of Butyl Tube Sealant to leading edge of T238 panel.
6. Field Notch panel seam and fold over end tabs of panels.

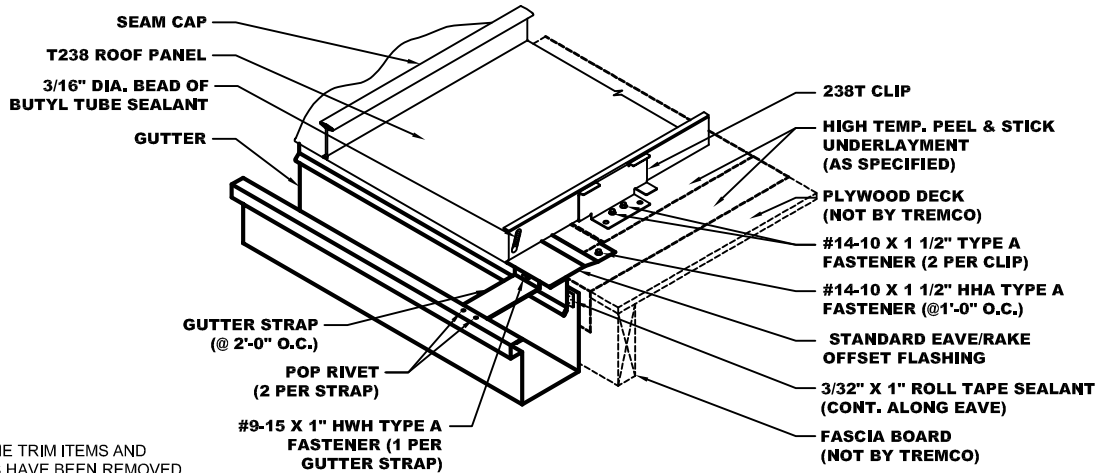

\*NOTE: SOME TRIM ITEMS AND FASTENERS HAVE BEEN REMOVED FOR CLARITY OF ISOMETRIC DETAIL.

# EAVE DRIP GUTTER DETAIL

T238  
C-2

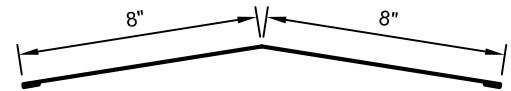
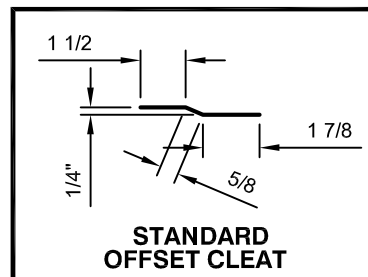
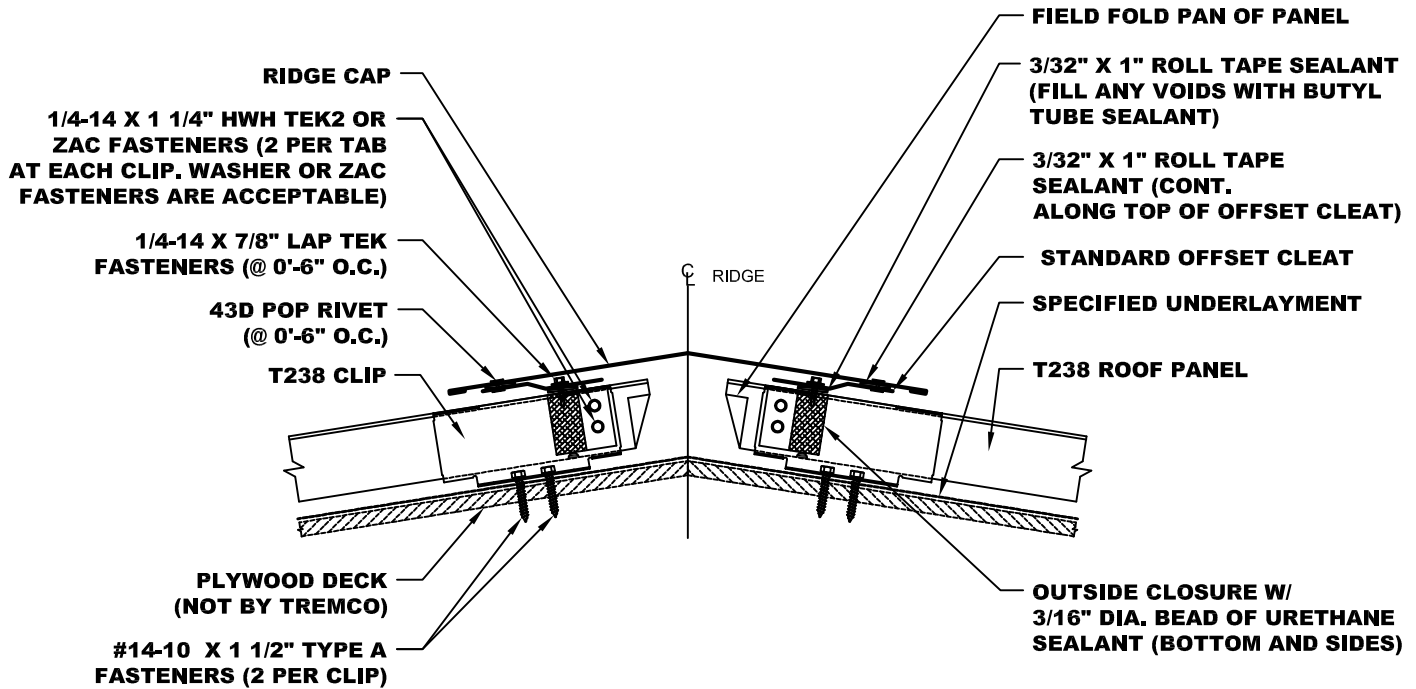

- NOTES:**
1. Ridge Cap and Standard Offset Cleat to run from out of wall to out of wall.
  2. Using a panning tool, fold up the pan of the panel at the ridge.
  3. Install T238 panels and apply a 3/16" Dia. bead of Urethane Tube Sealant in the pan of the panel and up the the vertical legs where the foam closure will be placed.
  4. Install Metal Closure Cover over the Foam Closure and secure to panel with (2) 1/4-14 x 1 1/4" HWH Tek2 or ZAC Fasteners, making sure to fasten through the clip to provide fixed point.
  5. Ridge Cap laps 2". Apply 3/32" x 1" Butyl Tape and Pop Rivet trims to Standard Offset Cleat with Pop Rivets at 0'-6" O.C.

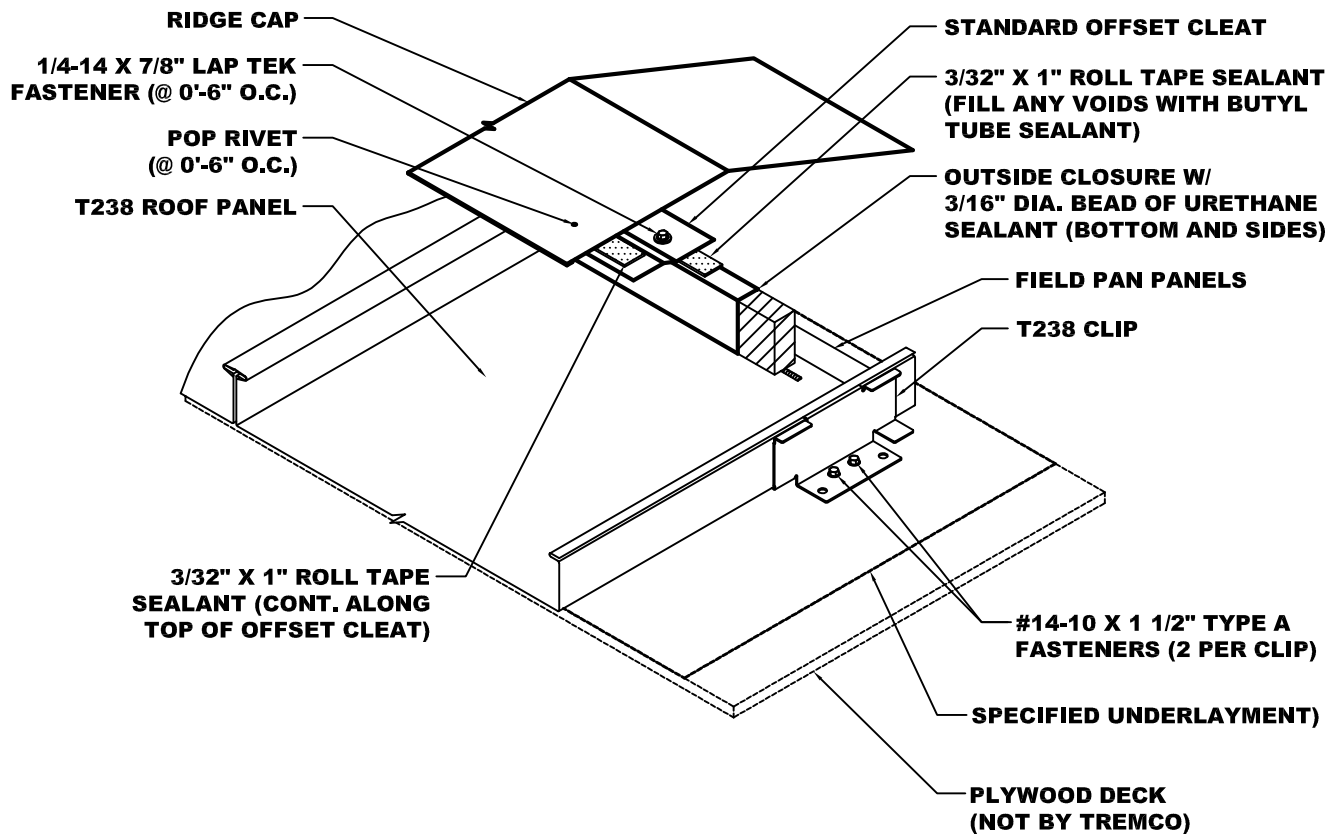

\*NOTE: SOME TRIM ITEMS AND FASTENERS HAVE BEEN REMOVED FOR CLARITY OF ISOMETRIC DETAIL.

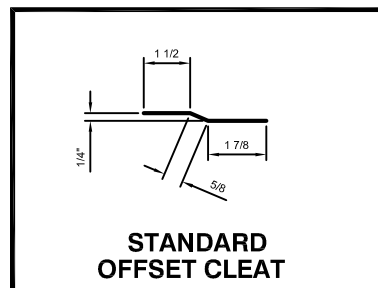

- NOTES:**
1. Ridge Cap and Standard Offset Cleat to run from out of wall to out of wall.
  2. Using a panning tool, fold up the pan of the panel at the ridge.
  3. Install T238 panels and apply a 3/16" Dia. bead of Urethane Tube Sealant in the pan of the panel and up the the vertical legs where the foam closure will be placed.
  4. Install Metal Closure Cover over the Foam Closure and secure to panel with (2) 1/4-14 x 1 1/4" HWH Tek2 or ZAC Fasteners, making sure to fasten through the clip to provide fixed point.
  5. Ridge Cap laps 2". Apply 3/32" x 1" Butyl Tape and Pop Rivet trims to Standard Offset Cleat with Pop Rivets at 0'-6" O.C.



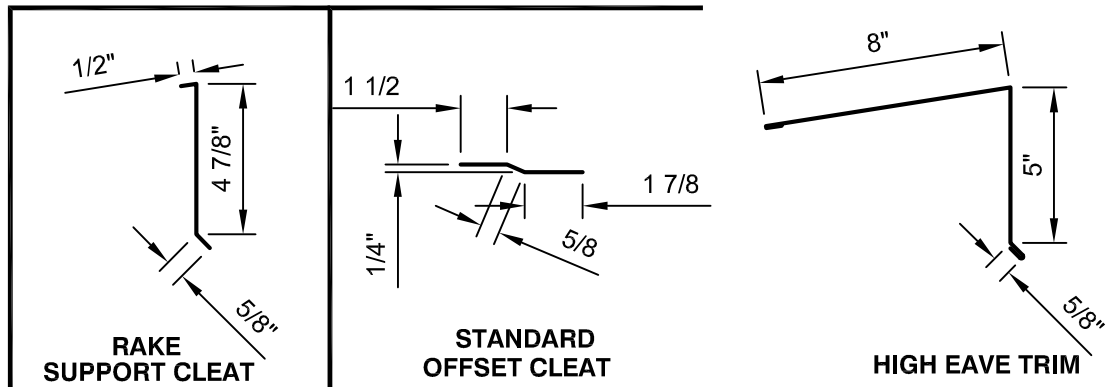
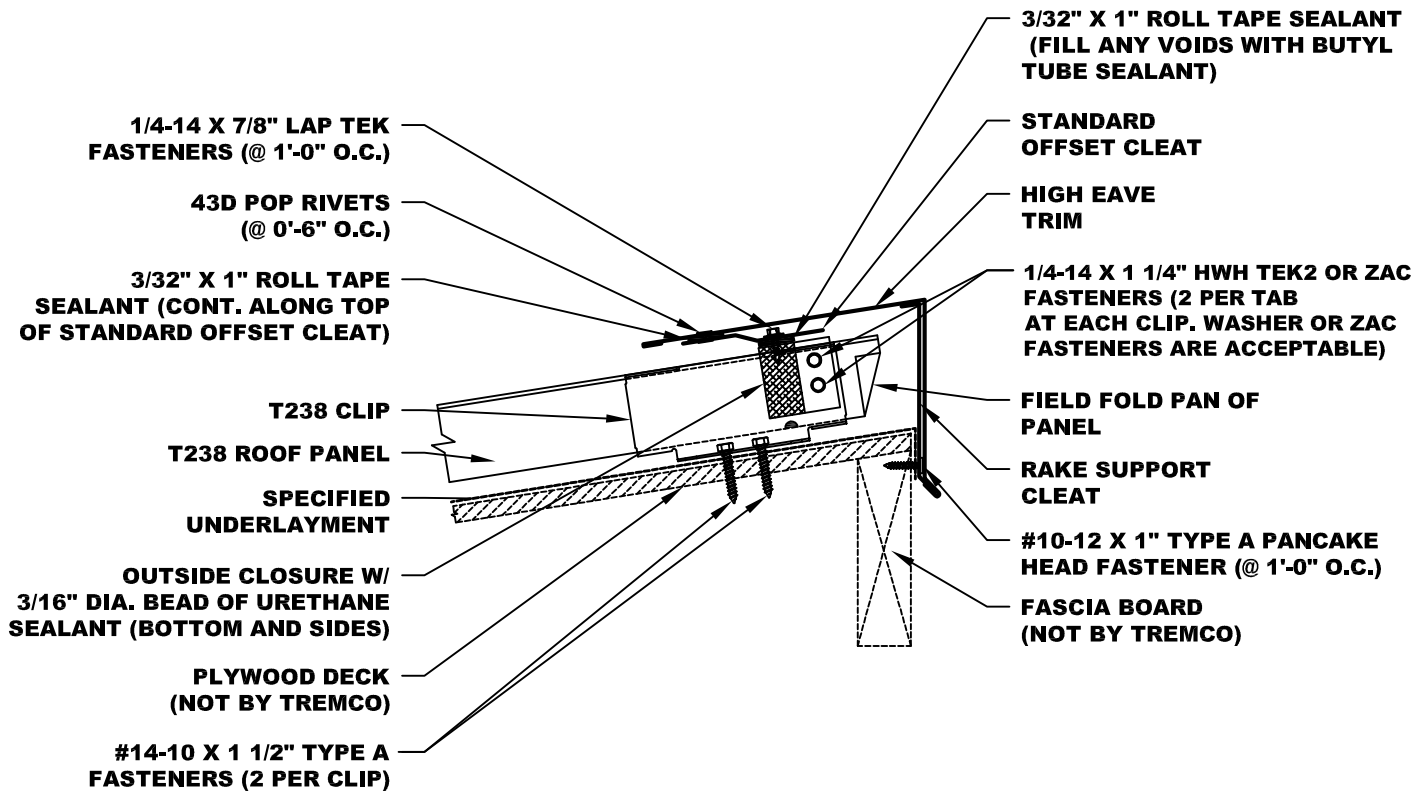

from out to out of building.

2. Attach Rake Support Cleat to fascia board with #10-12 x 1" Type A Pancake Head Fasteners at 1'-0" O.C.
3. Apply a 3/16" Dia. bead of Urethane Sealant to the pan and up the vertical legs of the panel where the Foam Outside Closure will be placed. Install Metal Closure Cover over Foam Outside Closure and attach to panels and clip with (2) 1/4-14 x 1 1/4" HWH Tek2 or ZAC Fasteners to provide a fixed point. Attach 1/4" Offset Cleat to Outside Closures with 1/4-14 x 7/8" Lap Tek fasteners at 1'-0" O.C.
4. Apply a continuous line of 3/32" x 1" Roll Tape Sealant to the top flange of the Standard Offset Cleat.
5. High Eave Trim to lap 2". Apply 3/32" x 3/8" Butyl Tape or Butyl Tube Sealant In trim laps and Pop Rivet flashing. Offset Cleat will butt joint.

\*NOTE: SOME TRIM ITEMS AND FASTENERS HAVE BEEN REMOVED FOR CLARITY OF ISOMETRIC DETAIL.

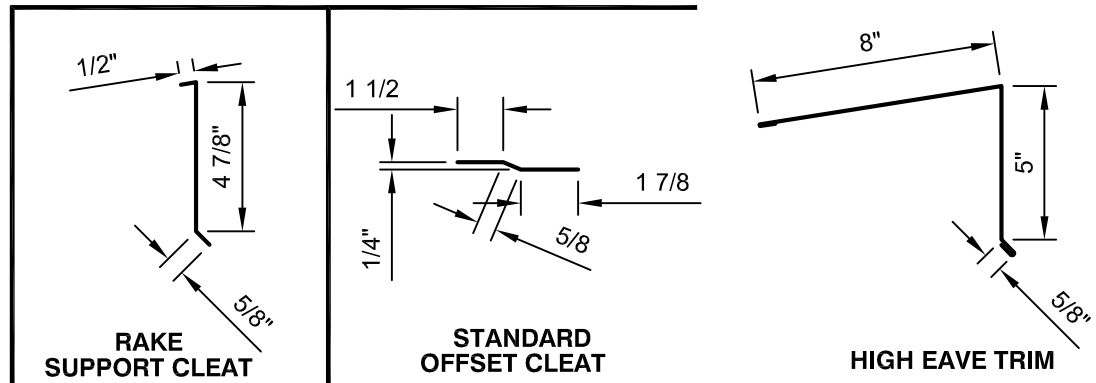
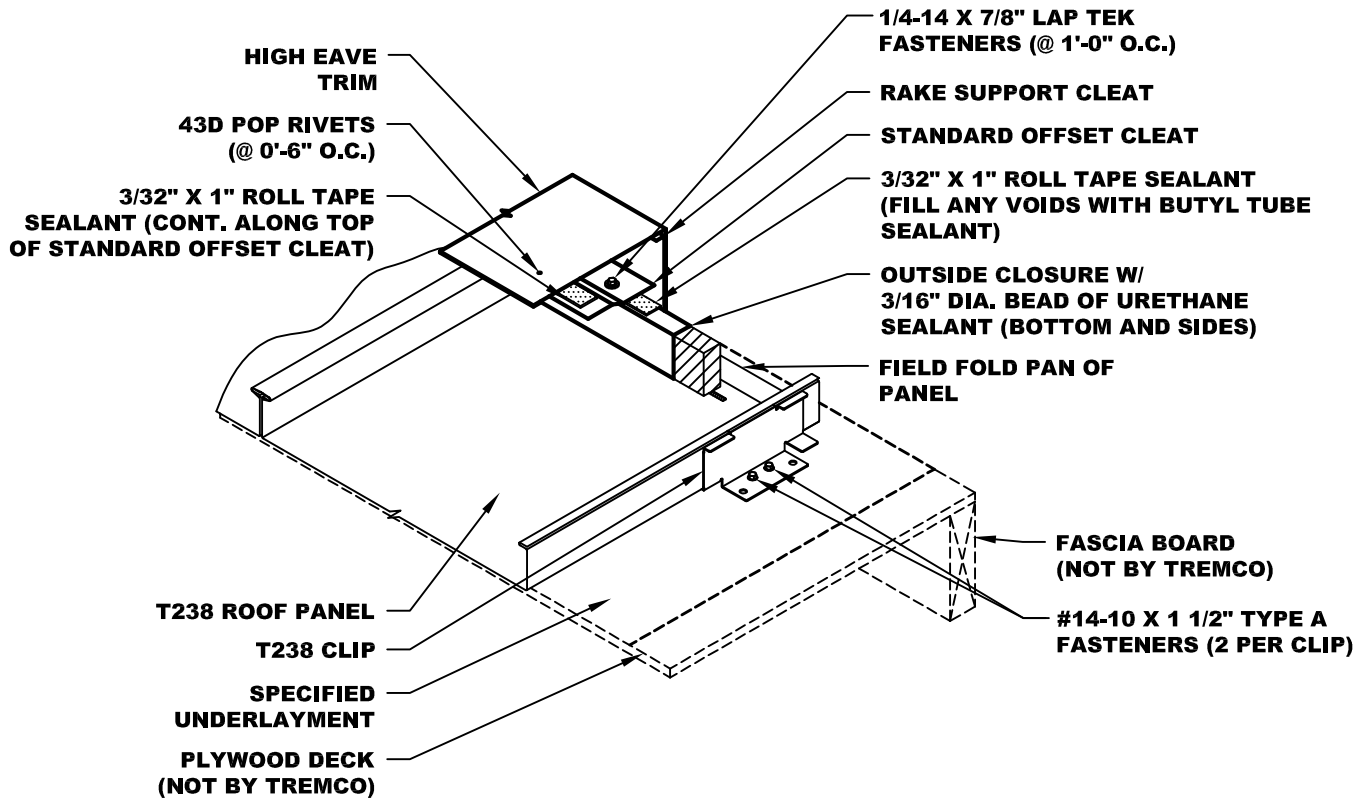

- NOTES:**
1. High Eave Trim, Rake Support Cleat) and Standard Offset Cleat to run from out to out of building.
  2. Attach Rake Support Cleat to fascia board with #10-12 x 1" Type A Pancake Head Fasteners at 1'-0" O.C.
  3. Apply a 3/16" Dia. bead of Urethane Sealant to the pan and up the vertical legs of the panel where the Foam Outside Closure will be placed. Install Metal Closure Cover over Foam Outside Closure and attach to panels and clip with (2) 1/4-14 x 1 1/4" HWH Tek2 or ZAC Fasteners to provide a fixed point. Attach 1/4" Offset Cleat to Outside Closures with 1/4-14 x 7/8" Lap Tek fasteners at 1'-0" O.C.
  4. Apply a continuous line of 3/32" x 1" Roll Tape Sealant to the top flange of the MT-38 (Standard Offset Cleat).
  5. High Eave Flashing to lap 2". Apply 3/32" x 3/8" Butyl Tape or Butyl Tube Sealant in trim laps and Pop Rivet flashing. Offset Cleat will butt joint.

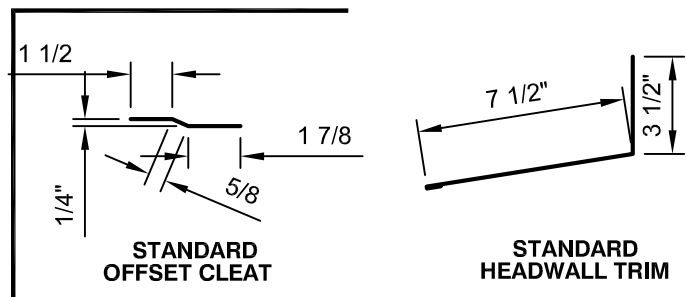
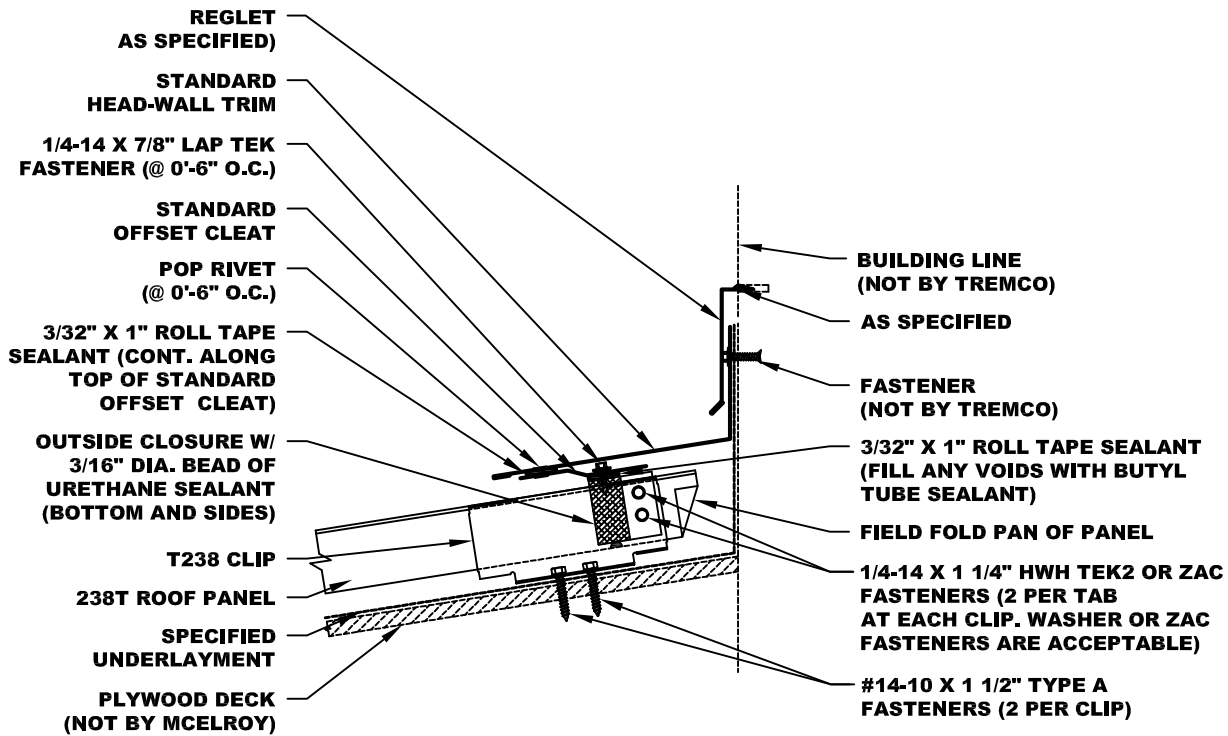

- NOTES:**
1. Standard Headwall Trim and Standard Offset Cleat to run from out to out of building.
  2. Apply a 3/16" Dia. bead of Urethane Sealant to the pan and up the vertical legs of the panel where the Foam Outside Closure will be placed. Install Metal Closure Cover over Foam Outside Closure and attach to panels and clip with (2) 1/4-14 x 1 1/4" HWH Tek2 or ZAC Fasteners to provide a fixed point.
  3. Apply a continuous line of 3/32" x 1" Roll Tape Sealant to the top flange of the Metal Outside Closure. Attach 1/4" Offset Cleat to Outside Closure with 1/4-14 x 7/8" Lap Tek Fasteners at 0'-6" O.C.
  4. Apply a continuous line of 3/32" x 1" Roll Tape Sealant to the top flange of the Offset Cleat.
  5. Standard Headwall Trim to lap 2". Apply 3/32" x 3/8" Butyl Tape or Butyl Tube Sealant in trim laps and Pop Rivet flashing. Standard Offset Cleat will butt joint.

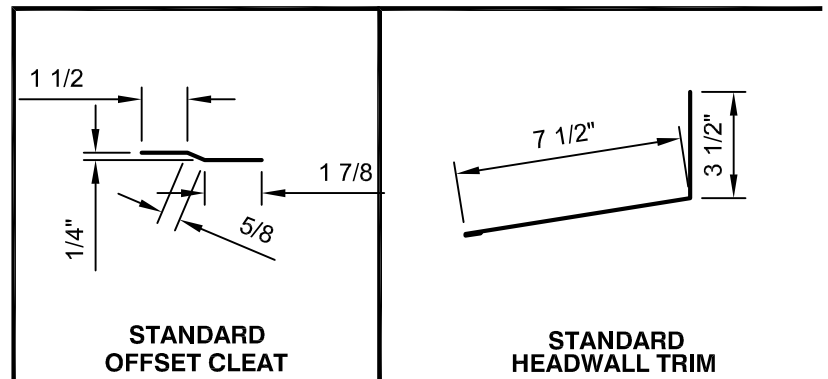
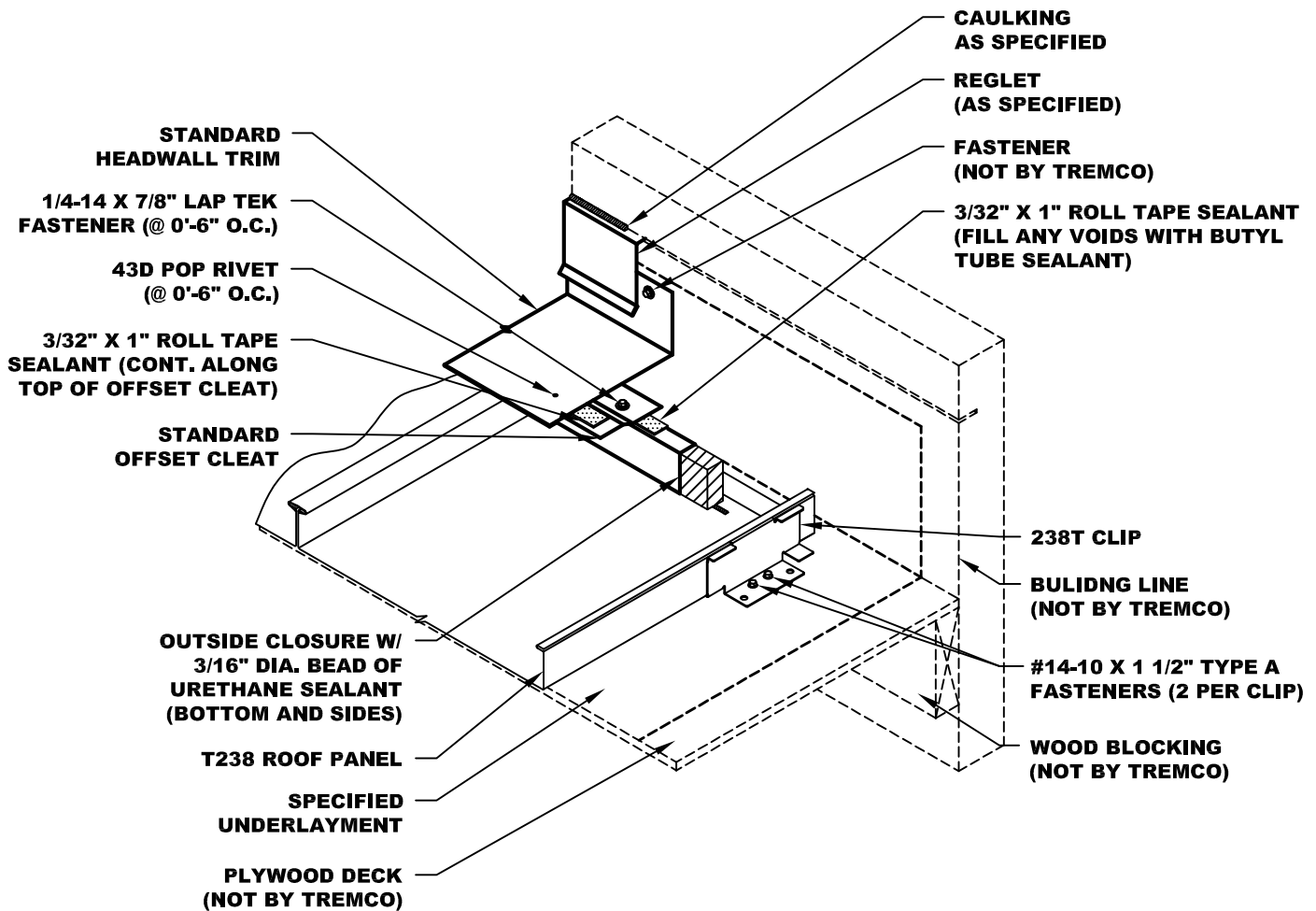

\*NOTE: SOME TRIM ITEMS AND FASTENERS HAVE BEEN REMOVED FOR CLARITY OF ISOMETRIC DETAIL.

- NOTES:**
1. Standard Headwall Trim and Standard Offset Cleat to run from out to out of building.
  2. Apply a 3/16" Dia. bead of Urethane Sealant to the pan and up the vertical legs of the panel where the Foam Outside Closure will be placed. Install Metal Closure Cover over Foam Outside Closure and attach to panels and clip with (2) 1/4-14 x 1 1/4" HWH Tek2 or ZAC Fasteners to provide a fixed point.
  3. Apply a continuous line of 3/32" x 1" Roll Tape Sealant to the top flange of the Metal Outside Closure. Attach 1/4" Offset Cleat to Outside Closure with 1/4-14 x 7/8" Lap Tek Fasteners at 0'-6" O.C.
  4. Apply a continuous line of 3/32" x 1" Roll Tape Sealant to the top flange of the Offset Cleat.
  5. Standard Headwall Trim to lap 2". Apply 3/32" x 3/8" Butyl Tape or Butyl Tube Sealant in trim laps and Pop Rivet flashing. Standard Offset Cleat will butt joint.

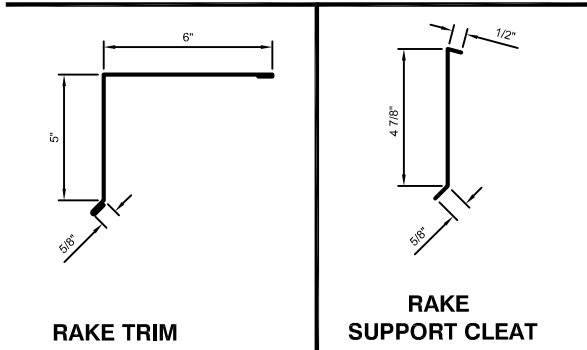
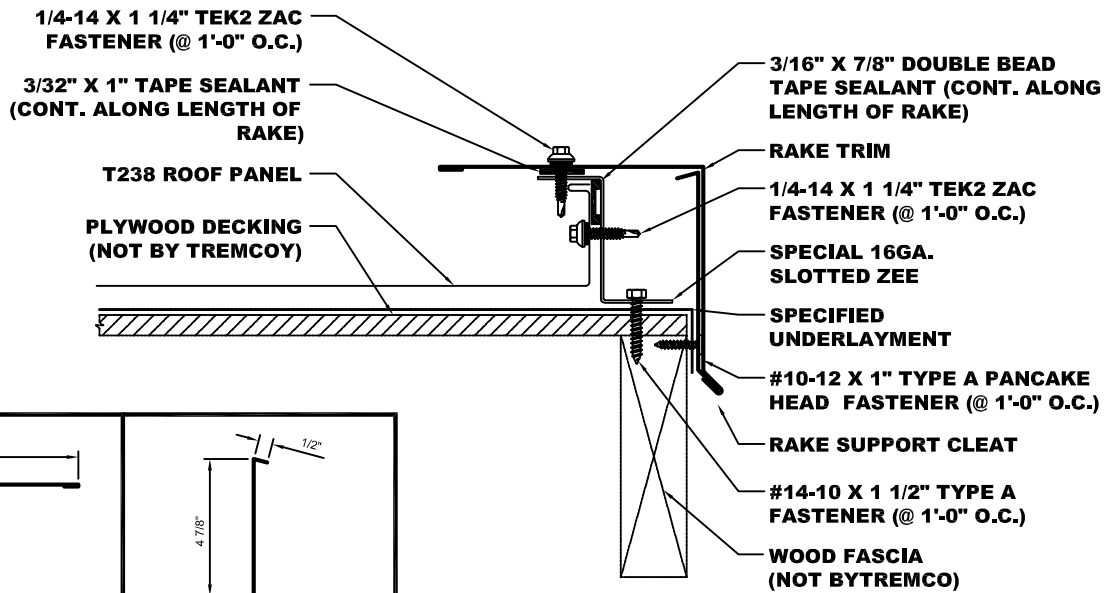

- NOTES:**
1. Rake Trim, Rake Support Cleat and Special 16ga. Slotted Zee to run from eave to ridge.
  2. Attach MT-SLOT-Z238 (Special 16ga. Slotted Zee) to decking with #14-10 x 1 1/2" HWH Type A Fasteners at 1'-0" O.C.
  3. Apply a continuous bead of 3/16" x 7/8" Double Bead Tape Sealant to the vertical leg of the 238T panel. Install 238T panel and hold in place on the Slotted Zee with clamps. Fasten panel to Slotted Zee with 1/4-14 x 1 1/4" Tek2 ZAC Fasteners at 1'-0" O.C.
  4. Apply a continuous bead of 3/32" x 1" Roll Tape Sealant to the top of the Slotted Zee and attach Rake Trim with 1/4-14 x 1 1/4" Tek2 ZAC Fasteners at 1'-0" O.C.
  5. Trim pieces lap 2". Apply 3/32" x 3/8" Butyl Tape or Butyl Tube Sealant in trim laps and Fasten to trims.

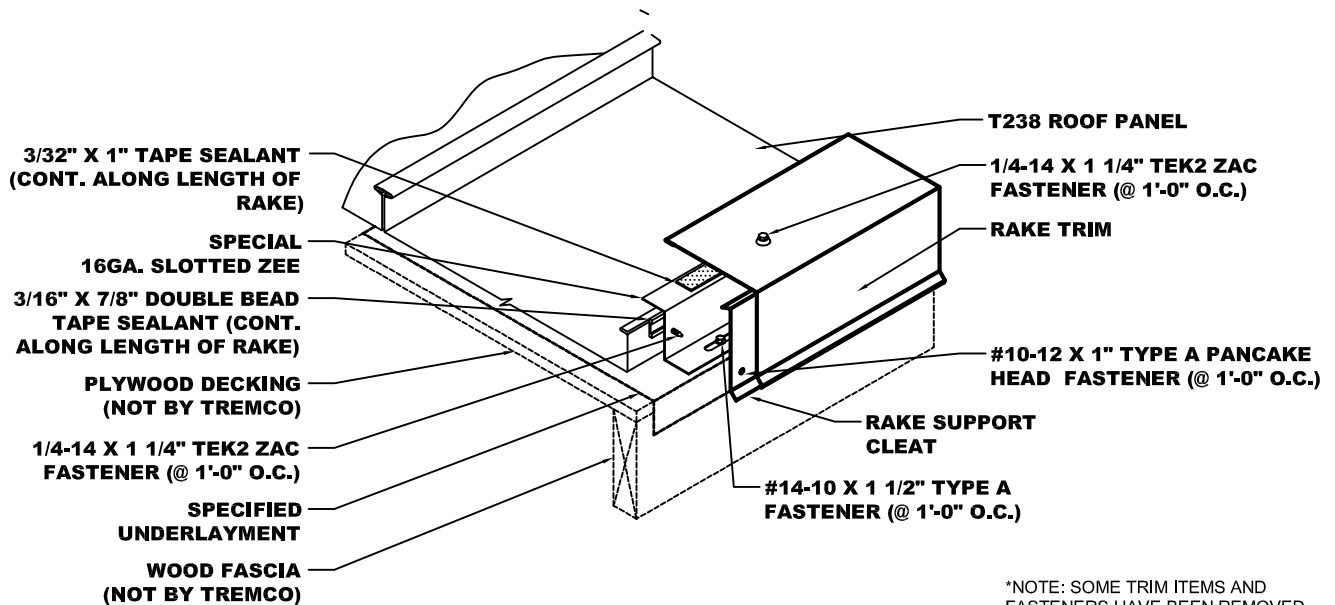

\*NOTE: SOME TRIM ITEMS AND FASTENERS HAVE BEEN REMOVED FOR CLARITY OF ISOMETRIC DETAIL.

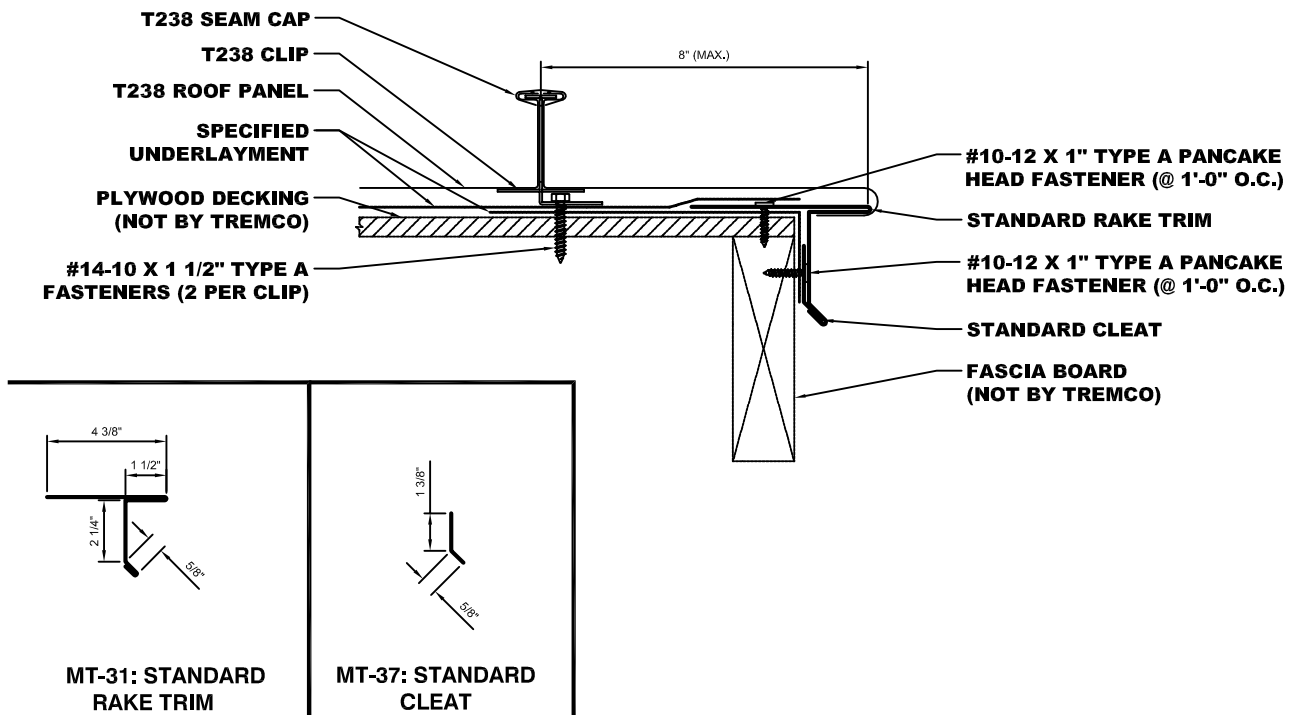

- NOTES:**
1. Rake Trim and Standard Cleat) to run from eave to ridge.
  2. Attach Standard Cleat to Fascia Board with #10-12 x 1" Type A Pancake Head Fasteners at 1'-0" O.C.
  3. Attach Rake Trim to Standard Cleat and fasten to Plywood Decking with #10-12 x 1" Type A Pancake Head Fasteners at 1'-0" O.C.
  4. Field cut leading edge of panel and fold panel down 180°.

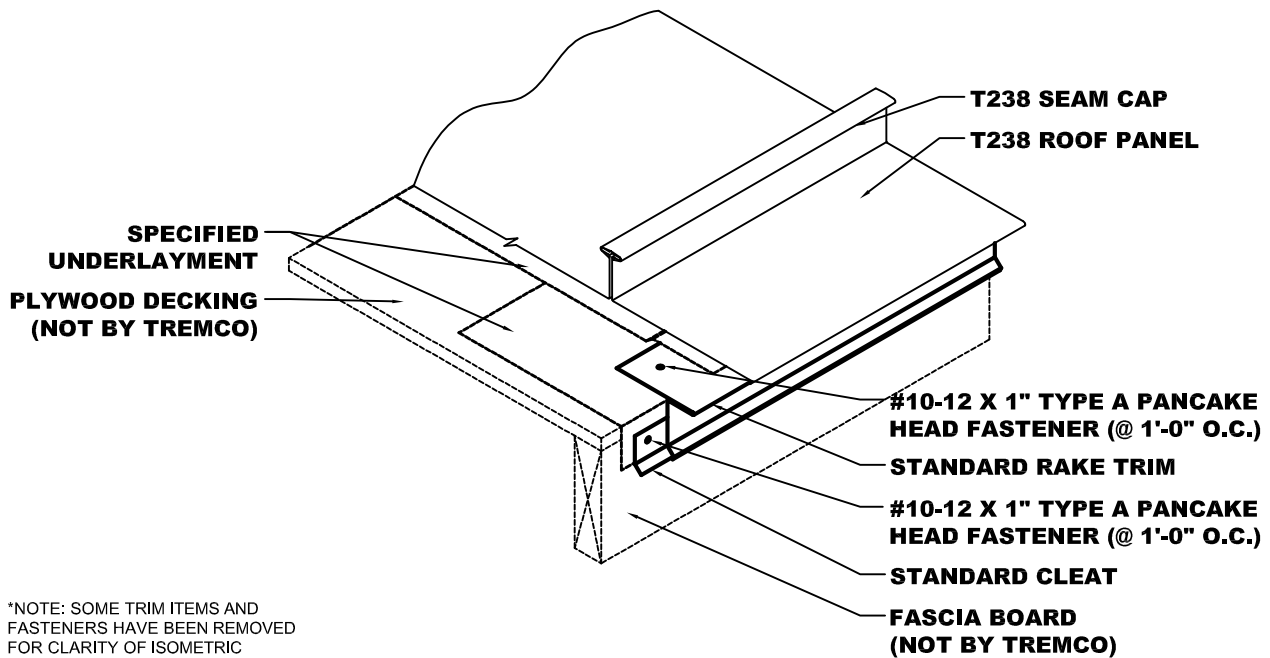

\*NOTE: SOME TRIM ITEMS AND FASTENERS HAVE BEEN REMOVED FOR CLARITY OF ISOMETRIC DETAIL.

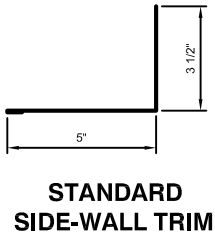
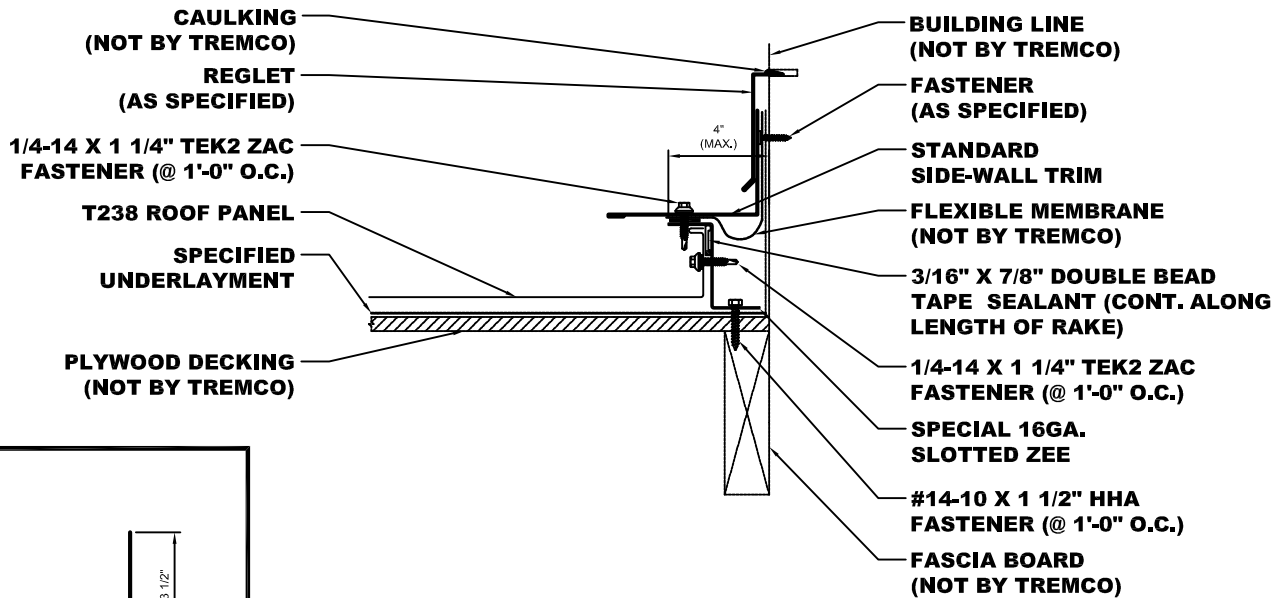

- NOTES:**
1. Standard Side-Wall Trim to run from Eave to Ridge.
  2. Attach Special 16ga. Slotted Zee to decking with #14-10 x 1 1/2" HWH Type A Fasteners at 1'-0" O.C.
  3. Apply a continuous run of 3/16" x 7/8" Double Bead Tape Sealant to the vertical leg of the T238 panel. Install T238 panel and hold in place on the Slotted Zee with clamps. Fasten panel to Slotted Zee with 1/4-14 x 1 1/4" Tek2 Zac Fasteners at 1'-0" O.C.
  4. Apply a continuous run of 3/32" x 1" Roll Tape Sealant to the top of the Slotted Zee and attach Standard Side-Wall Trim with 1/4-14 x 1 1/4" Tek2 ZAC Fasteners at 1'-0" O.C.
  5. Trim pieces lap 2". Apply 3/32" x 3/8" Butyl Tape or Butyl Tube Sealant in trim laps and Fasten to trims.

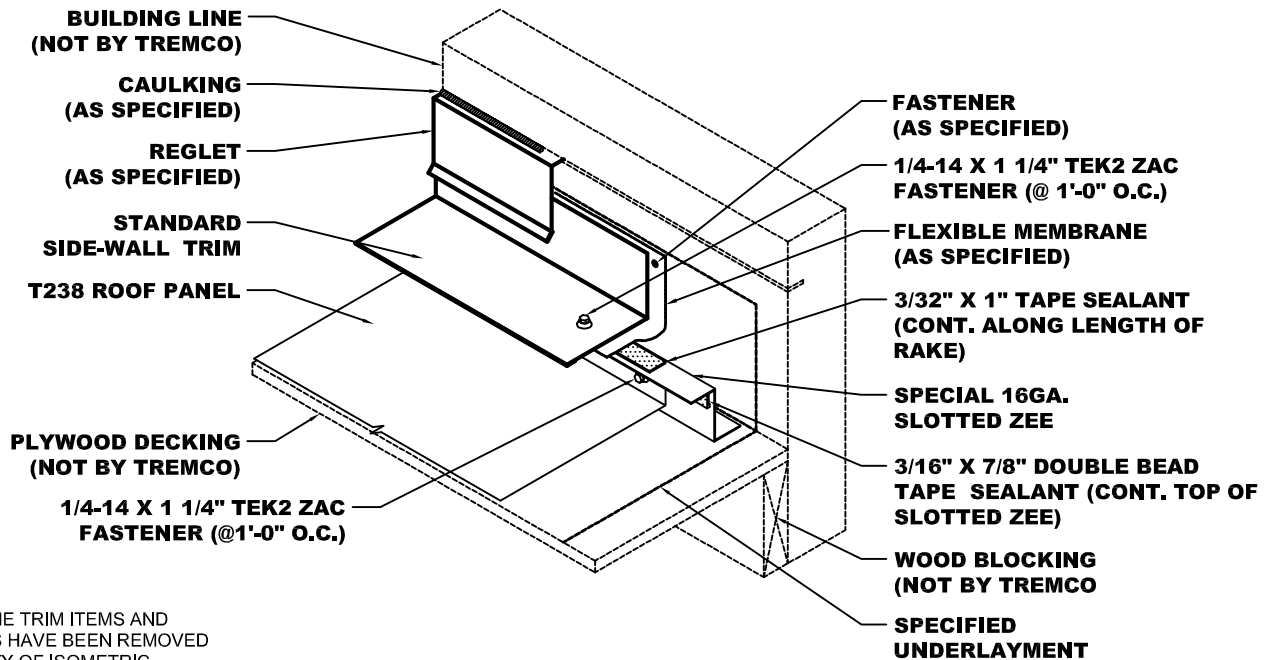

\*NOTE: SOME TRIM ITEMS AND FASTENERS HAVE BEEN REMOVED FOR CLARITY OF ISOMETRIC DETAIL.

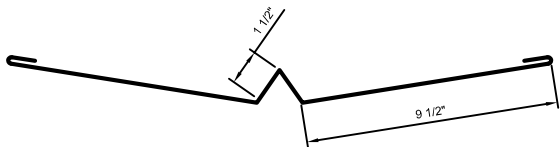
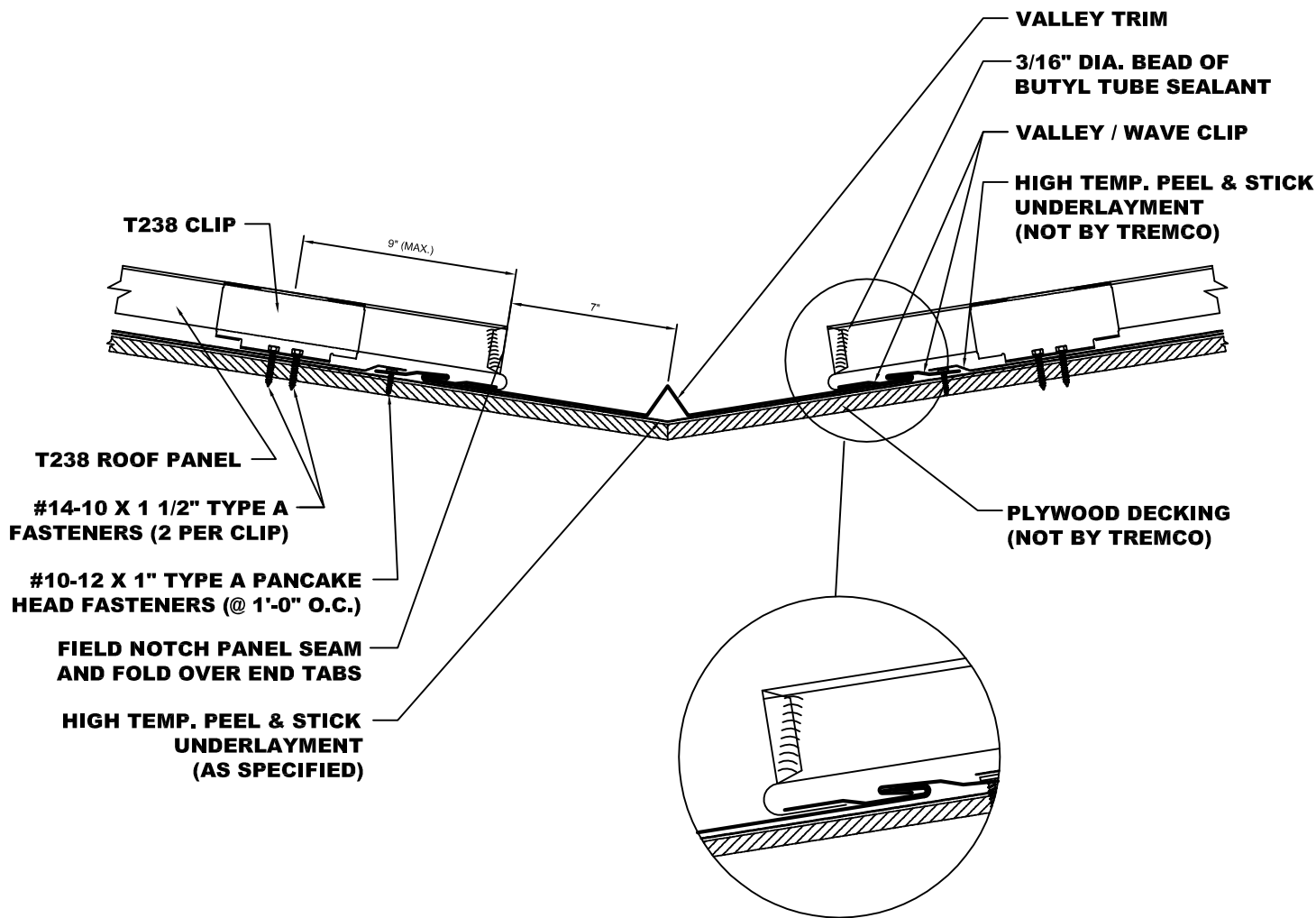

**VALLEY TRIM**

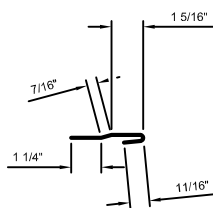

**VALLEY / WAVE CLIP**

- NOTES:**
1. Install Trim from eave to ridge. Valley Trim pieces lap 6". Place 3/32" x 1" Butyl Tape or a 3/16" Dia. bead of Butyl Tube Sealant In laps.
  2. Cut panels at required bevel for valley condition.
  3. Attach Valley / Wave Clip with #10-12 x 1" Type A Pancake Head fasteners at 1'-0" O.C.



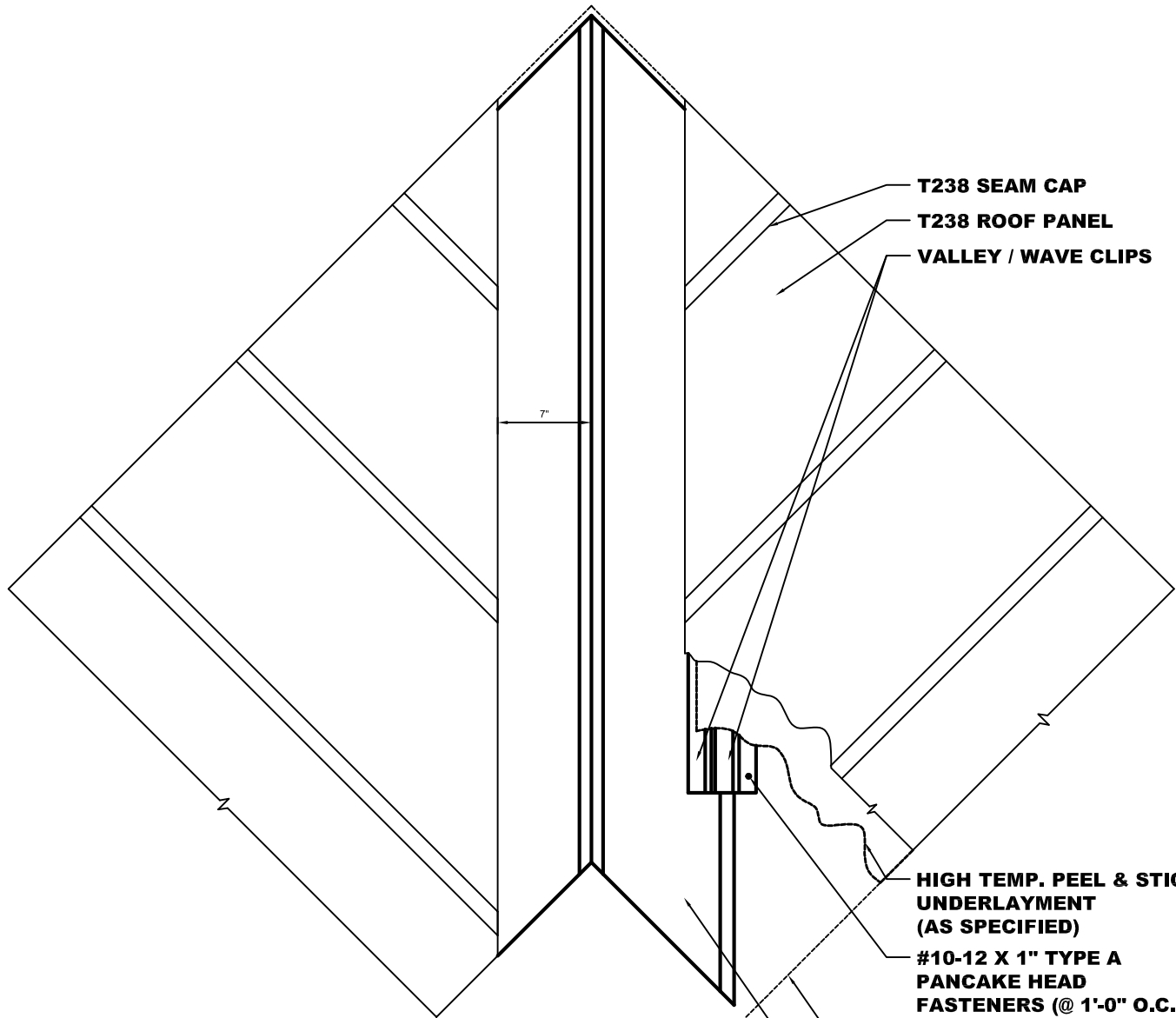

T238 SEAM CAP  
 T238 ROOF PANEL  
 VALLEY / WAVE CLIPS

HIGH TEMP. PEEL & STICK UNDERLAYMENT (AS SPECIFIED)  
 #10-12 X 1" TYPE A PANCAKE HEAD FASTENERS (@ 1'-0" O.C.)

PLYWOOD DECKING (NOT BY TREMCO)

VALLEY TRIM

\*NOTE: SOME TRIM ITEMS AND FASTENERS HAVE BEEN REMOVED FOR CLARITY OF ISOMETRIC DETAIL.

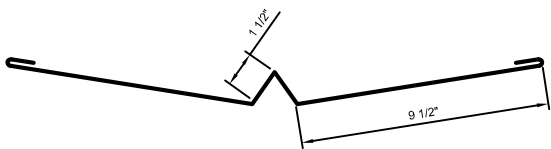

VALLEY TRIM

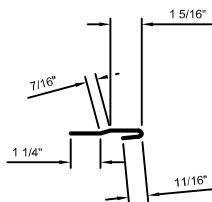

VALLEY / WAVE CLIP

- NOTES:** 1. Install Valley Trim from eave to ridge. Valley Trim pieces lap 6". Place 3/32" x 1" Butyl Tape or a 3/16" Dia. bead of Butyl Tube Sealant in laps.  
 2. Cut panels at required bevel for valley condition.  
 3. Attach Valley / Wave Clip with #10-12 x 1" Type A Pancake Head fasteners at 1'-0" O.C.

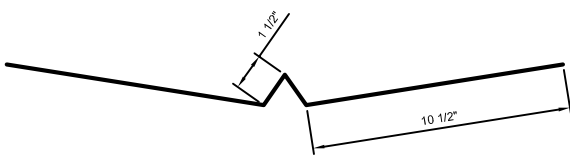
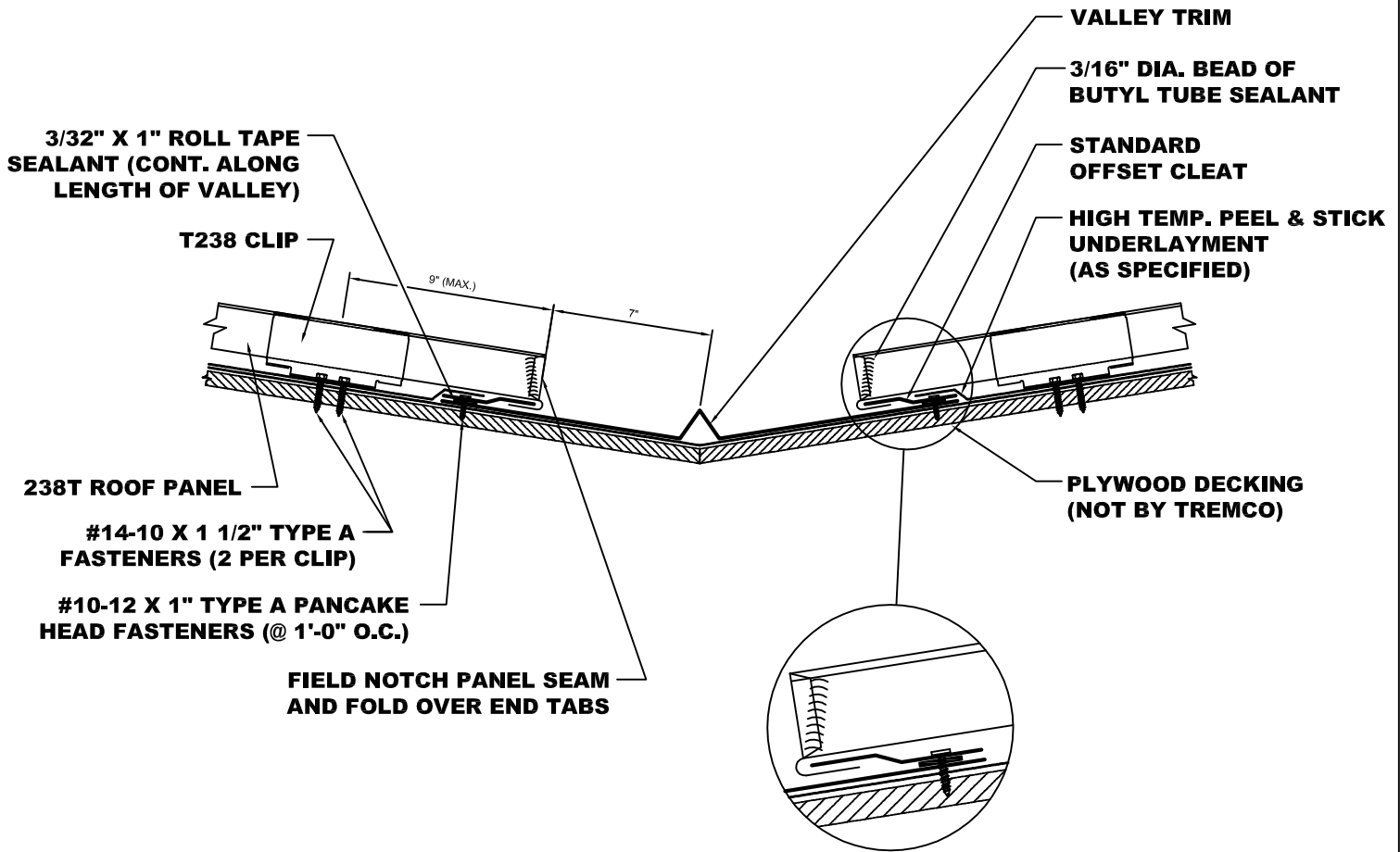

**VALLEY TRIM**

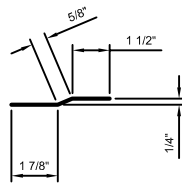

**STANDARD OFFSET CLEAT**

- NOTES:**
1. Install Valley Trim from eave to ridge. Valley Trim pieces lap 6". Place 3/32" x 1" Butyl Tape or a 3/16" Dia. bead of Butyl Tube Sealant in laps.
  2. Cut panels at required bevel for valley condition.
  3. Apply a continuous line of 3/32" x 1" Roll Tape Sealant up both sides of Valley Trim.
  4. Install Standard Offset Cleat with #10-12 x 1" Type A Pancake Head fasteners at 1'-0" O.C.

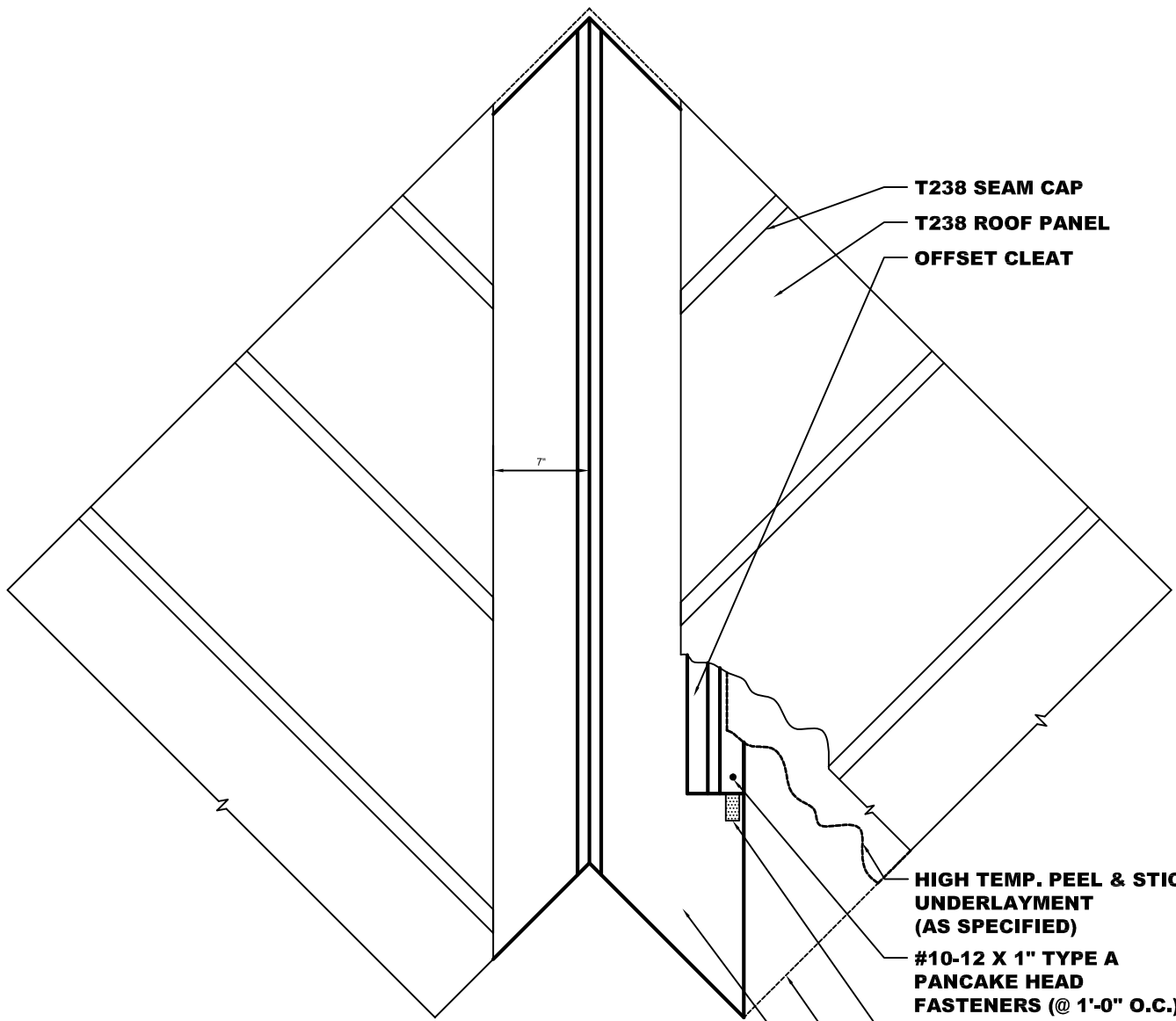

\*NOTE: SOME TRIM ITEMS AND FASTENERS HAVE BEEN REMOVED FOR CLARITY OF ISOMETRIC DETAIL.

- T238 SEAM CAP
- T238 ROOF PANEL
- OFFSET CLEAT
- HIGH TEMP. PEEL & STICK UNDERLAYMENT (AS SPECIFIED)
- #10-12 X 1" TYPE A PANCAKE HEAD FASTENERS (@ 1'-0" O.C.)
- 3/32" X 1" ROLL TAPE SEALANT (CONT. ALONG LENGTH OF VALLEY)
- PLYWOOD DECKING (NOT BY TREMCO)
- VALLEY TRIM

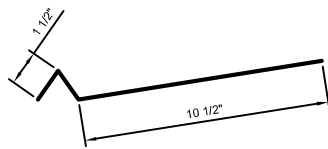

VALLEY TRIM

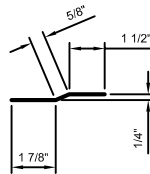

STANDARD OFFSET CLEAT

- NOTES:**
1. Install Valley Trim from eave to ridge. Valley Trim pieces lap 6". Place 3/32" x 1" Butyl Tape or a 3/16" Dia. bead of Butyl Tube Sealant in laps.
  2. Cut panels at required bevel for valley condition.
  3. Apply a continuous line of 3/32" x 1" Roll Tape Sealant up both sides of Valley Trim.
  4. Attach Standard Offset Cleat) with #10-12 x 1" Type A Pancake Head fasteners at 1'-0" O.C.

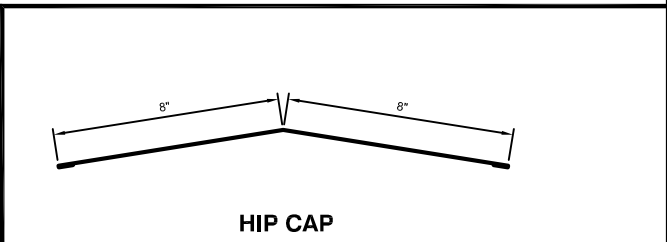
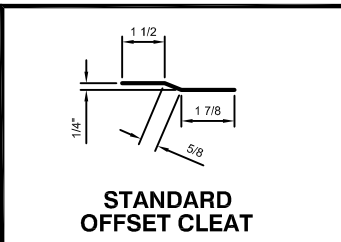
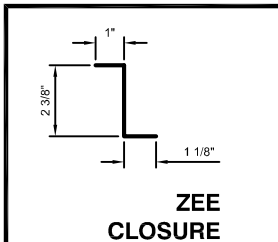
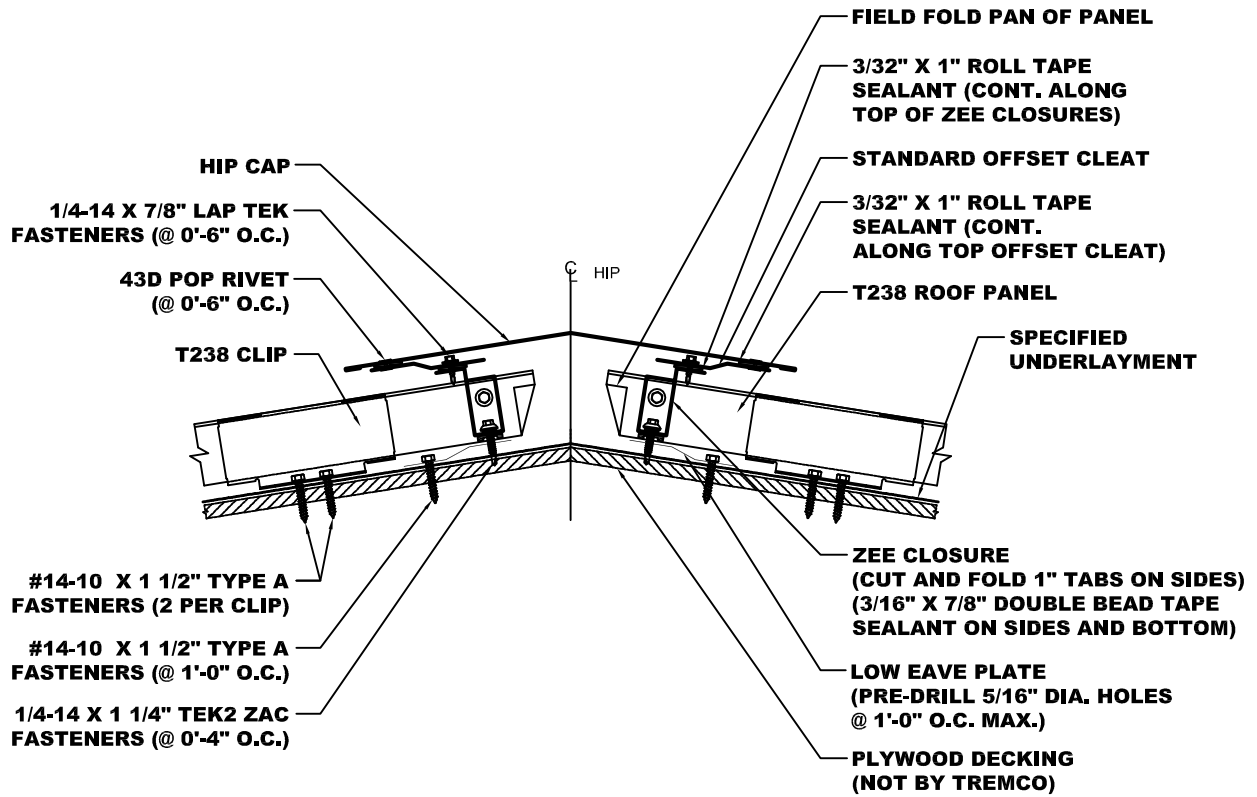

- NOTES:**
1. Hip Cap to run from Eave to Ridge. Standard Offset Cleat to run from Ridge to Eave.
  2. Using a panning tool, fold up the pan of the panel at the Hip.
  3. Install T238 panels as directed in this manual.
  4. Cut individual Zee Closures with 1" Side Tabs from the Zee Closure . Apply a 3/16" x 7/8" Double Bead Tape Sealant to the bottom and sides of Zee Closures and install 2" down from end of panel. Fasten with 1/4-14 x 1 1/4" Tek2 ZAC fasteners at 0'-4" (Max.).
  5. Hip Cap laps 2". Apply 3/32" x 1" Butyl Tape and Pop Rivet trims to Standard Offset Cleat with Pop Rivets at 0'-6" O.C.

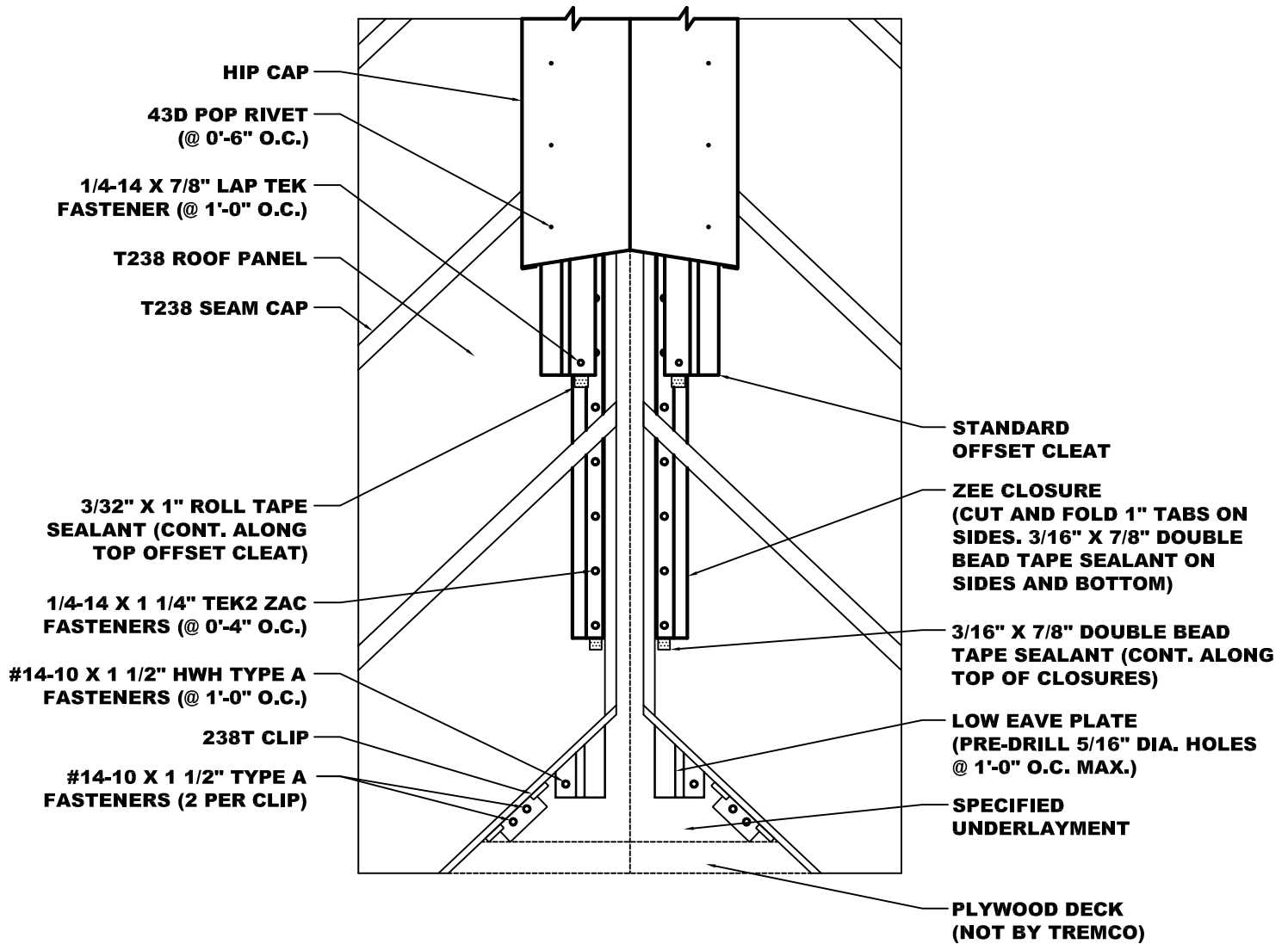

\*NOTE: SOME TRIM ITEMS AND FASTENERS HAVE BEEN REMOVED FOR CLARITY OF ISOMETRIC DETAIL.

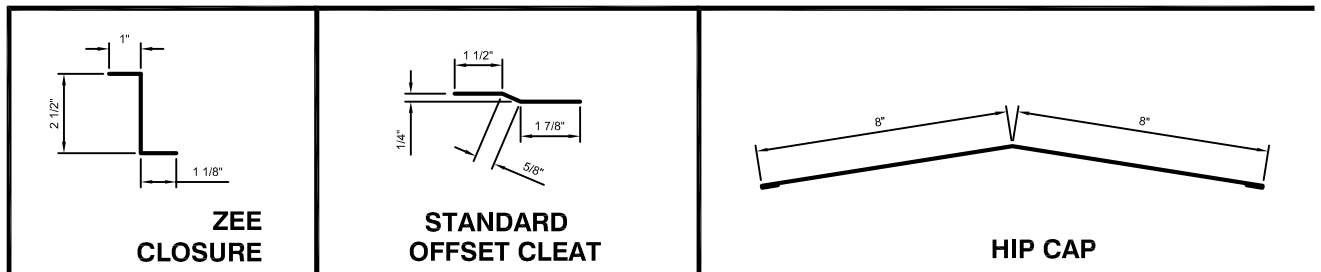

- NOTES:**
1. Hip Cap to run from Eave to Ridge. Standard Offset Cleat to run from Ridge to Eave.
  2. Using a panning tool, fold up the pan of the panel at the Hip.
  3. Install T238 panels as directed in this manual.
  4. Cut individual Zee Closures with 1" Side Tabs from the Zee Closure. Apply a 3/16" x 7/8" Double Bead Tape Sealant to the bottom and sides of Zee Closures and install 2" down from end of panel. Fasten with 1/4-14 x 1 1/4" Tek2 ZAC fasteners at 0'-4" (Max.).
  5. Hip Cap laps 2". Apply 3/32" x 1" Butyl Tape and Pop Rivet trims to Standard Offset Cleat with Pop Rivets at 0'-6" O.C.

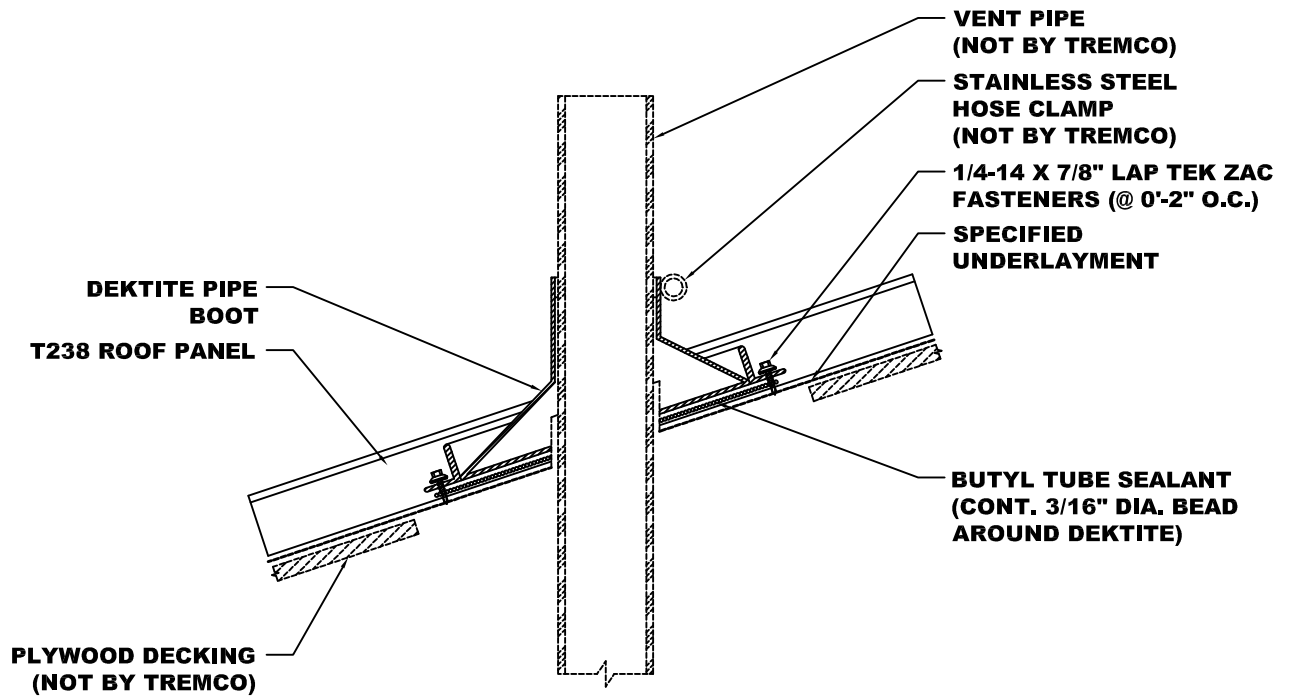

- NOTES:**
1. Cut hole in panel 1" larger than pipe diameter. If installing over a solid substrate, over-cut hole in substrate so fastener do not pin system from thermal movement.
  2. Cut hole in top of Dektite Boot so that it fits snugly around pipe. Apply a 3/16" Dia. bead of Tube Butyl
  3. Dektite boot **MUST** fit in pan of panel. Do not fasten to standing seams.

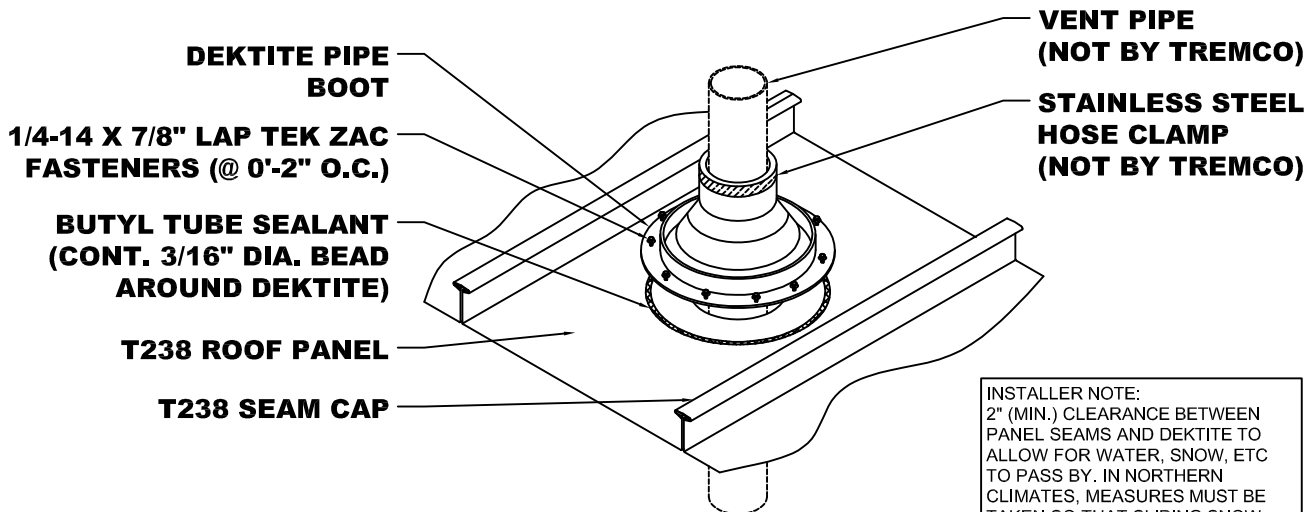

**INSTALLER NOTE:**  
 2" (MIN.) CLEARANCE BETWEEN  
 PANEL SEAMS AND DEKTITE TO  
 ALLOW FOR WATER, SNOW, ETC  
 TO PASS BY. IN NORTHERN  
 CLIMATES, MEASURES MUST BE  
 TAKEN SO THAT SLIDING SNOW  
 WILL NOT DAMAGE THE DEKTITE.

\*NOTE: SOME TRIM ITEMS AND  
 FASTENERS HAVE BEEN REMOVED  
 FOR CLARITY OF ISOMETRIC  
 DETAIL.

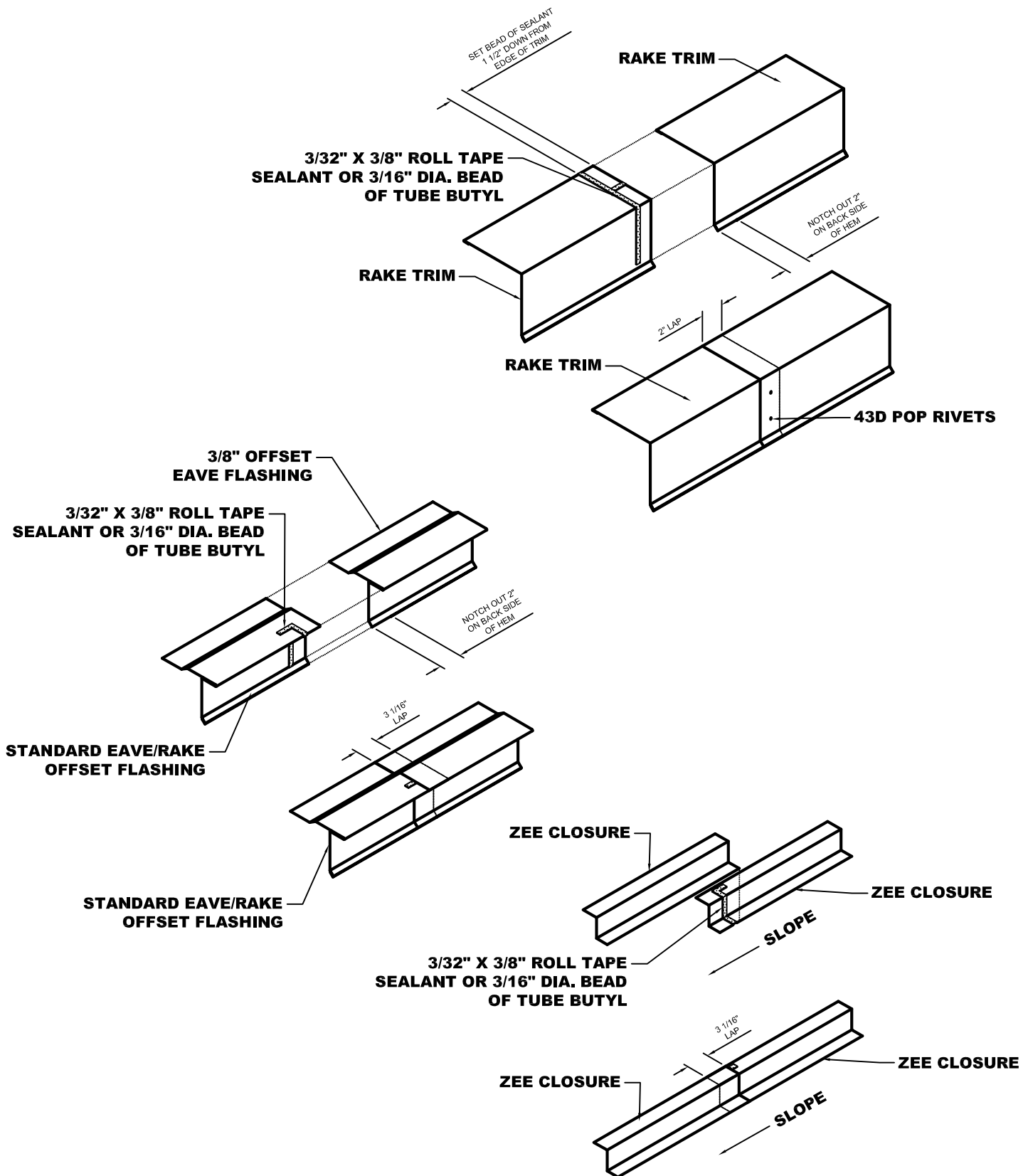

**NOTE:** 1. Apply 3/32" x 3/8" Roll Tape Sealant or a 3/16" Dia. bead of Tube Butyl 1 1/2" back from the edge of the trim. Also, apply a piece of tape sealant or bead of Tube Butyl as a Pigtail to completely seal joint.  
 2. Notch the hems on the upper trim piece 2" so that the trim will fit flat in the lap joint.  
 3. Secure trim laps with Pop Rivets as shown above.

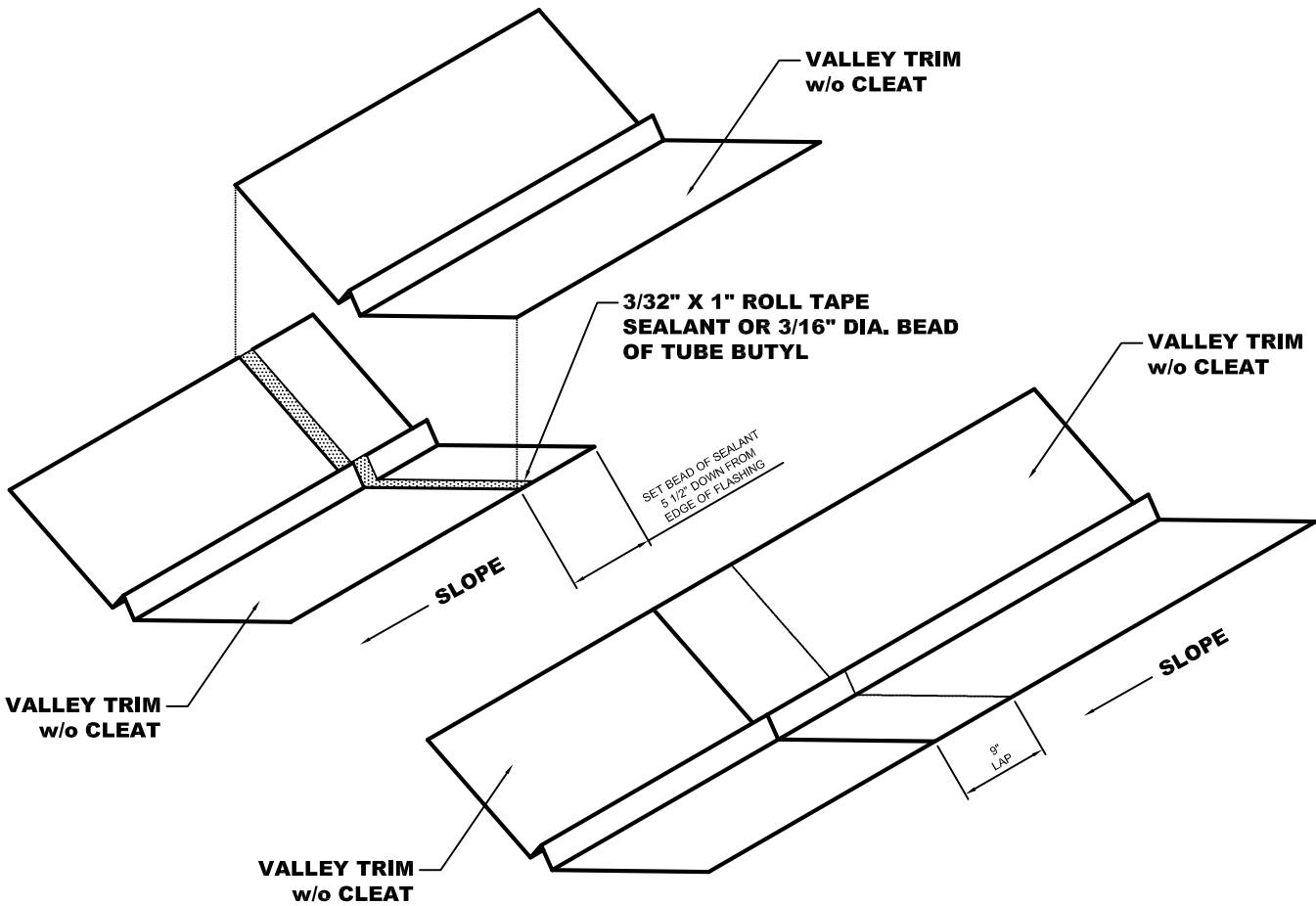
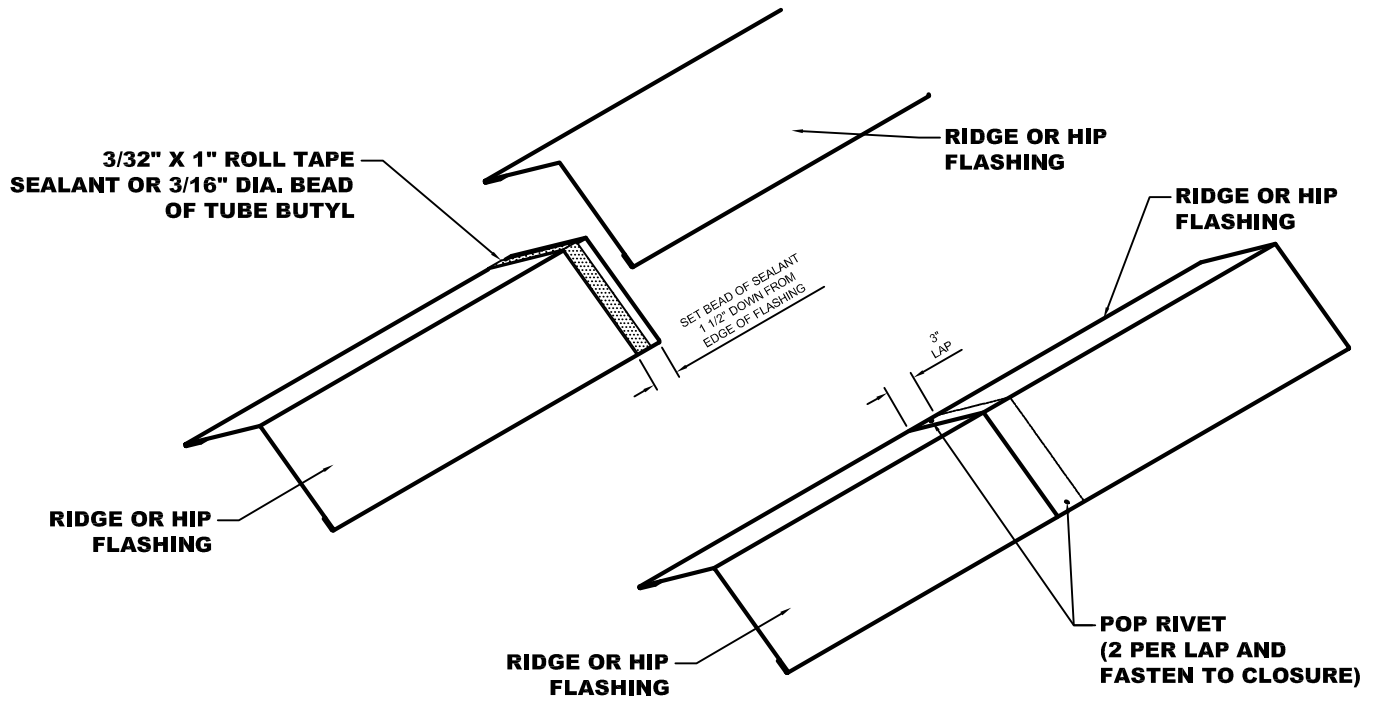

**NOTE:** 1. Apply 3/32" x 1" Roll Tape Sealant or a 3/16" Dia. bead of Tube Butyl 1 1/2" back from the edge of the trim.  
 2. Notch the hems on the upper trim piece 2" so that the trim will fit flat in the lap joint.  
 3. Secure trim laps with Pop Rivets as shown above.



# **TREMCO**®

ROOFING & BUILDING MAINTENANCE

TREMCO INCORPORATED  
3735 GREEN RD. • BEACHWOOD, OH • 44122 • 216-292-5000